

KCB SLING · THAILAND

KCB SLING * TRACK

PRODUCT CATALOG

NO MORE GUESSING FOR LIFTING

◆ WIRE ROPE SLING ◆ POLYESTER SLING ◆ RIGGING EQUIPMENT ◆ ACCESSORIES

HIGH SAFETY HIGH QUALITY EXPERT & HONEST

KCB SLING (THAILAND) CO., LTD. · WWW.KCBSLING.CO.TH

WELCOME

ENGINEER YOUR LIFT.

This catalogue brings together everything KCB Sling builds, imports and certifies — wire rope and wire-rope slings, TRACK polyester webbing and round slings, ratchet lashings, and a full range of rigging accessories. Every breaking-load value, every dimension and every working-load limit on these pages is drawn from the manufacturer's published data and verified by our engineering team.

WHAT WE STAND FOR

HIGH SAFETY

Safety is the design brief, not a slogan. Every assembly carries a Safety Factor that allows for shock loads.

HIGH QUALITY

Certified materials, controlled processes and verified output — quality that lasts.

EXPERT & HONEST

Decades of engineering know-how, transparent specifications and fair pricing.

OUR PROMISE

Every assembly leaving our workshop is treated as if it were carrying our own family. That is the standard. That is the only standard.

WHAT WE SUPPLY

Wire Rope Sling

Forged Alloy Shackles & Hooks

Master Links & Master Link Assembly

Chain Blocks & Lever Hoists

TRACK · Our Polyester Brand

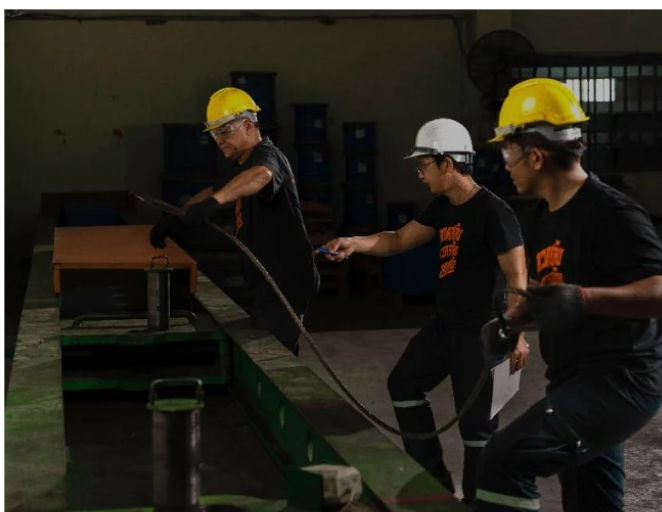

IN-HOUSE PROOF-LOAD TESTING



TRACK SLING PRODUCTION, PATHUM THANI

FOUR CHAPTERS · ONE STANDARD

CONTENTS

FRONT MATTER

Welcome — Engineer Your Lift	01
Quality & Standards	04

01 · SLING ENGINEERING & SAFETY

Every Lift Uses One Of Three Hitches	06
How Rated Capacity Is Calculated	08
Splice & Termination Efficiency	10
Steel Grade — Strength At Same Diameter	12
When To Remove A Sling From Service	14
Storage & Care	16
Glossary Of Key Terms	18

02 · WIRE ROPE SLING

A Rope Is A Machine	19
Wire Rope Constructions	21
Sheave, Drum & D/d Ratio	23
COMPACT WIRE ROPE SLING 35 / 35P	25
COMPACT WIRE ROPE SLING 18 / 18P	27
COMPACT WIRE ROPE SLING 8 / 8P	29
COMPACT WIRE ROPE SLING 6 / 6P	31
STANDARD WIRE ROPE SLING 6×19	33
Elevator Ropes	35
Shipping — 6×24 & Anchor Mooring	37
6×19M · 6×7 · 7×7	39
6×S(19) & 6×W(19) + IWRC	41
Gondola Ropes	43
GAC, Control Cable & PVC-Coated	45
Wire Rope Sling WLL & Sling Angle	47
Wire Rope Sling WLL — EIPS	49
Braid Sling Capacity — 3 & 4-Part	51
Terminations, Damage & Inspection	53
Application Guide & Do / Don't	55

03 · POLYESTER SLING

The TRACK Polyester Range	57
Webbing Sling — WLL Chart	59
Round Sling — WLL Chart	61
Why Choose Polyester	63

04 · RIGGING EQUIPMENT

Bolt-Type Anchor Shackle · Type 2130	64
Bolt-Type Chain (D) Shackle · Type 2150	66
Welded Master Link · Type 344	68
Wire Rope Clip · U-Bolt · Type 450	70
Closed Spelter Socket · Type 417	72
Aluminium Ferrules — EN 13411-3	74
Grade 80 & 100 Chain Slings	76
Hand Chain Blocks & Lever Hoists	78

05 · SERVICE & SUPPORT

Engineered Solutions	80
Get In Touch	82

About Us	03
Industries We Serve	05

Sling Angle & Hitch Capacity	07
Rated Capacity — Worked Examples	09
Terminations & End Fittings	11
Strength & Weight Reference	13
Inspection Intervals & Method	15
Things Every User Should Know	17

Construction, Class & Grade	20
Strand Construction & Lay Direction	22
Rope Selection By Application	24
STANDARD WIRE ROPE SLING 35 / 35P	26
STANDARD WIRE ROPE SLING 18 / 18P	28
STANDARD WIRE ROPE SLING 8 & 8×19	30
STANDARD WIRE ROPE SLING 6 · 6×36WS / 6×31WS	32
STANDARD WIRE ROPE SLING 6×29F & 4	34
Oil & Gas — Drill / Sand Line	36
Fishing & Combination — c-Mermaid	38
Small-Diameter Rope — Which Construction?	40
Seale vs Warrington — Which Wire Pattern?	42
Gondola Ropes — 4 & 5 Strand	44
Strands & Speciality Steel Wire	46
Wire Rope Sling WLL — IPS	48
Multi-Part Braid Slings	50
Braid Sling Capacity — 6 & 8-Part	52
Mechanical Damage & Termination Efficiency	54
Conversion Tables	56

Polyester Webbing Sling	58
Polyester Round Sling	60
TRACK Ratchet Strap with Custom Hook	62

Screw-Pin Anchor Shackle · Type 209	65
Screw-Pin Chain (D) Shackle · Type 210	67
Master Link Assembly · Type 347	69
Open Spelter Socket · Type 416	71
Resin Socketing Compound	73
Flemish Sleeves & Swage Studs	75
Alloy Chain Sling WLL — Grade 80 / 100	77
Trolleys, Clamps & Beam Anchors	79

Ordering & Rope Identification	81
--------------------------------------	----

ABOUT US

LIFTING IS ENGINEERING.

KCB Sling (Thailand) Co., Ltd. has spent more than twenty years equipping Thailand’s construction, oil & gas, marine, manufacturing and offshore industries with lifting and rigging equipment that meets the world’s toughest standards. Every assembly we build begins with certified raw material, passes through engineered design, and ends with a proof-load test and a serialised test certificate that ties the finished product back to its material lot.

We import certified raw materials from the world’s leading mills — high-grade wire rope to API 9A; forged, quenched & tempered alloy shackles, hooks and sockets; DNV 2.7-1 approved alloy master links; and chain blocks and lever hoists. Our own TRACK-brand polyester slings and ratchet lashings are manufactured to EN-1492-1, EN-1492-2 and EN-12195-2 at our facility in Pathum Thani.

<p>20+ YEARS EXPERIENCE</p>	<p>3,000+ ACTIVE CUSTOMERS</p>	<p>100% CERTIFIED MATERIALS</p>	<p>24/7 ENGINEERING SUPPORT</p>
--	---	--	--

WHAT WE SUPPLY

- ◆ Wire rope & wire-rope slings — API 9A, BS EN 12385-4
- ◆ Forged alloy shackles, hooks & sockets — ASME B30.26
- ◆ DNV 2.7-1 alloy master links & components
- ◆ Grade 80 / 100 alloy chain, blocks & lever hoists
- ◆ TRACK — KCB’s own polyester sling & lashing brand

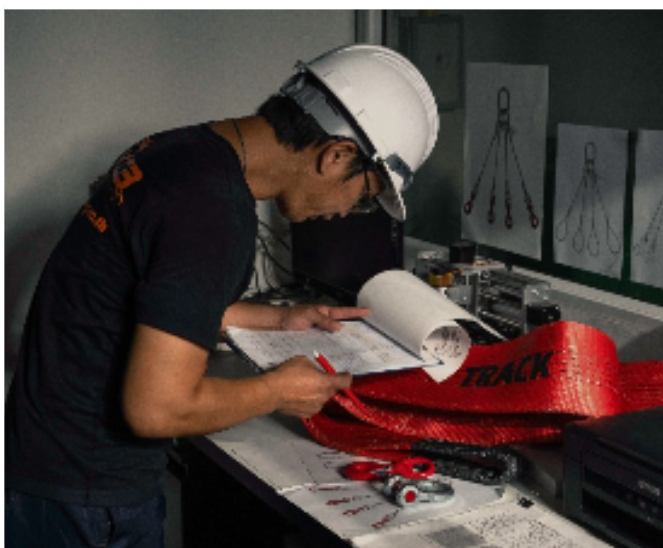

IN-HOUSE PROOF-LOAD TESTING



TRACK SLING PRODUCTION, PATHUM THANI

QUALITY & STANDARDS

QUALITY & STANDARDS

Certified at every step. Every wire rope, every alloy chain link and every polyester yarn batch can be traced back to its mill or factory. Every assembly is proof-loaded where the standard requires, individually serialized, and shipped with a test certificate that ties the product back to its raw-material lot.

STANDARD	SCOPE
BS EN 12385-4	Wire Rope — Stranded Ropes, General Lifting
BS EN 13414-1	Wire Rope Slings — General Lifting Service
BS EN 1492-1	Polyester Webbing Slings — Safety
BS EN 1492-2	Polyester Round Slings — Safety
BS EN 12195-2	Ratchet Lashings — Web Lashings
BS EN 1677-4	Master Links & Components
DNV 2.7-1	Offshore Containers — Type-Approved Sets
ASME B30.9	Slings — US Standard for Safe Operation
ASME B30.26	Rigging Hardware — Shackles, Hooks, Eye-Bolts
API 9A	Specification for Wire Rope (Oil & Gas)
JIS G 3525	Japanese Industrial Standard — Wire Rope
TIS 514-2527	Thai Industrial Standard — Wire Rope
ISO 9001	Quality Management System

WHY CERTIFICATION MATTERS

A certificate is only as good as the process behind it. For every assembly we build, our process is fixed and has no shortcuts:

<p>1 · 2</p> <p>INCOMING & DIMENSIONAL</p> <p>Incoming material inspection against the mill certificate, then dimensional check of all components.</p>	<p>3 · 4</p> <p>ASSEMBLE & PROOF-LOAD</p> <p>Assembly to the engineering drawing, then proof-load at the value required by the standard.</p>	<p>5 · 6</p> <p>INSPECT & CERTIFY</p> <p>Visual inspection after load, then issue of the serial-numbered test certificate.</p>
--	--	--

TÜV RHEINLAND & ISO 9001

KCB Sling carries a TÜV Rheinland product-quality mark and operates under an ISO 9001 quality-management system — your assurance that the process behind every certificate is audited and controlled.

INDUSTRIES WE SERVE

INDUSTRIES WE SERVE

Wherever heavy needs to move. KCB Sling equipment is at work today on construction sites, port quays, oil rigs, factory floors and ship yards across Thailand and South-East Asia. These are the sectors we know best.

CONSTRUCTION & INFRASTRUCTURE

Tower-crane rigging, pre-cast concrete erection, formwork hoists.

OIL, GAS & PETROCHEMICAL

Tandem heavy-lifts, vessel installation, pipe-rack work, planned shutdowns.

MARINE & OFFSHORE

DNV 2.7-1 offshore container slings, shipyard rigging, mooring hardware.

MANUFACTURING & HEAVY INDUSTRY

Mould handling, press tooling, machinery relocation, overhead crane slings.

POWER GENERATION

Transformer lifts, wind-turbine blade rigging, generator stator installation.

LOGISTICS & PROJECT CARGO

Container lashing, steel-coil securing, abnormal-load tie-down.

MINIMUM DESIGN SAFETY FACTORS

FACTOR	APPLICATION
10 : 1	Elevator
7 : 1	Polyester Sling
6 : 1	Crane, Hoist, Sling
5 : 1	Wire Rope
4 : 1	Chain Sling G80
2 : 1	Ratchet Lashing

Safety factor (SF) is the ratio of minimum breaking load to working load limit. The safety factor is an allowance for emergency situations and shock loads — it must never be consumed during normal lifting operations.

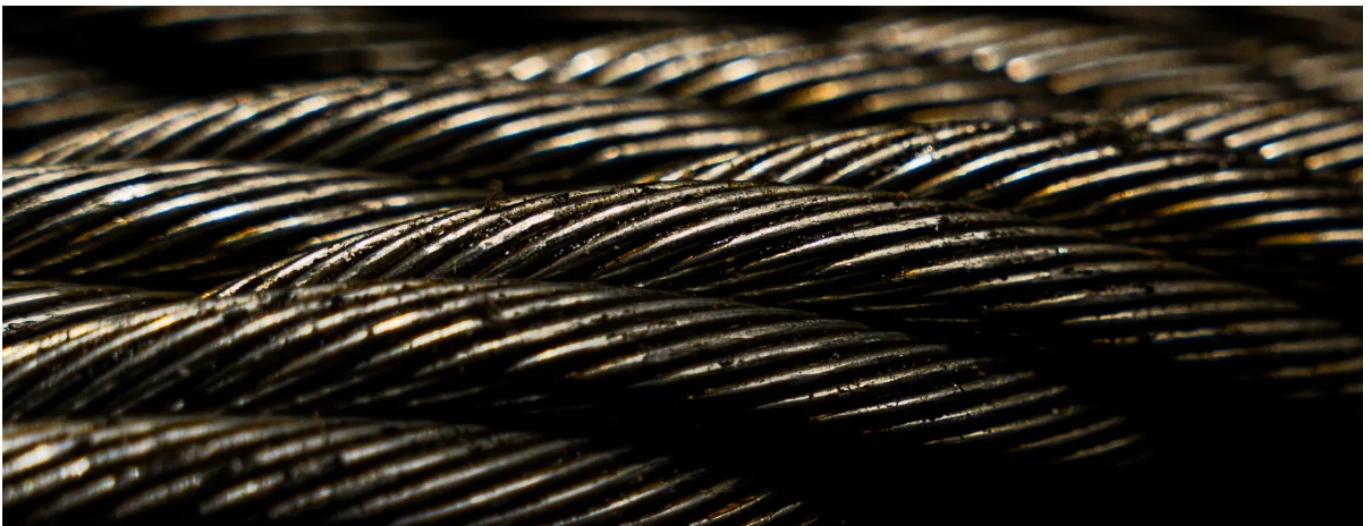



01

SLING ENGINEERING & SAFETY

The engineering behind every safe lift — rated capacity, hitches, the D/d ratio, terminations, inspection and the numbers that keep loads in the air. Reference data after the Wire Rope Technical Board.

[RATED CAPACITY](#)[HITCHES & ANGLES](#)[D/D RATIO](#)[TERMINATIONS](#)[INSPECTION](#)[SAFETY BULLETIN](#)

01 — SLING ENGINEERING

EVERY LIFT USES ONE OF THREE HITCHES

Vertical, choker and basket. The hitch you choose sets how much of a sling’s rated capacity you can actually use — and the angle of the legs changes the load carried by every leg. Get these two things right and most rigging mistakes disappear.

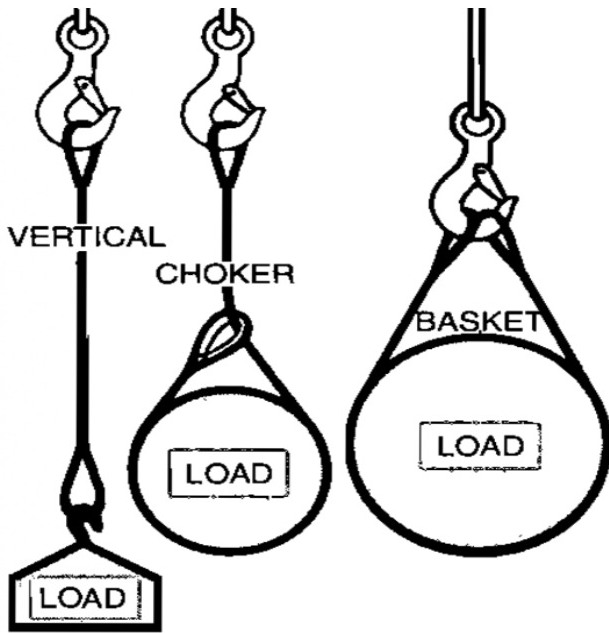

VERTICAL · CHOKER · BASKET — THE THREE BASIC HITCHES

01

VERTICAL (STRAIGHT)

A straight attachment from the lifting device to the load. Full rated load may be used, but never exceeded. A tagline should prevent the load from rotating.

02

CHOKER

The sling body passes through its own eye. Choking reduces rated capacity — at the choke point the body is bent and the splice efficiency does not add. Adjust by choke angle (table on the D/d page).

03

BASKET

The sling cradles the load with both legs rigged to the hook. Capacity is shared between the legs within the limits of the sling angle — rated on a D/d ratio of 15 (hand tucked) or 25 (mechanical).

SLING ANGLE CHANGES EVERYTHING



1,000 LB LOAD: 500 LB PER LEG AT 90°, 577 LB AT 60°, 707 LB AT 45°

Sling angle is measured from the horizontal plane. As the angle decreases, tension in each leg increases — sometimes dramatically. The same 1,000 lb load that puts 500 lb in each leg at 90° puts 707 lb in each leg at 45°.

30° IS THE FLOOR

Sling angles of less than 30° from horizontal shall not be used. Below this angle both the leg tension and the inward crushing force on the load rise sharply.

Source: Wire Rope Technical Board — Wire Rope Sling Users Manual, Third Edition. Rated capacities are for 6×19 and 6×36 classification rope, in tons of 2,000 lb, unless otherwise stated.

01 — SLING ENGINEERING

SLING ANGLE & HITCH CAPACITY — QUICK REFERENCE

Two numbers decide the rated capacity of every multi-leg lift: the sling angle and the hitch type. This page gives the exact factors so you can read the right capacity from any WLL table without doing trigonometry.

SLING ANGLE — LOAD PER LEG VS HORIZONTAL ANGLE

LOAD IN EACH SLING LEG VS HORIZONTAL ANGLE

HORIZ. ANGLE	LEG FACTOR	WHAT THIS MEANS
90° (straight up)	1.000	Full rated load — the safest and simplest rigging
60°	1.155	Each leg carries 15% more than at 90°
45°	1.414	Each leg carries 41% more — plan carefully
30°	2.000	Each leg carries twice the load — absolute limit
Below 30°	—	Do not rig — leg tension and crush force too high

HITCH TYPE — CAPACITY SUMMARY

HITCH	CAPACITY FACTOR	WHEN TO USE
Vertical — straight pull	1.00 × WLL	One leg, straight pull — full rated capacity
Choker hitch	0.75 × WLL	Rope wraps load — 25% capacity lost at choke
Vertical basket	2.00 × WLL	Both eyes on hook, load in bight — doubles capacity
2-leg bridle at 60°	1.73 × WLL	Steep legs — close to the 2.0× basket maximum
2-leg bridle at 45°	1.41 × WLL	Good balance of angle and capacity

THE MOST COMMON RIGGING MISTAKE

Rigging two sling legs wide apart and assuming the load is shared equally. Drop the legs to 30° from horizontal and the pair lifts no more than a single vertical sling — yet each leg is now loaded to twice the share you would expect. Keep sling angles tight. Always.

PUTTING IT TOGETHER — 2-LEG BRIDLE WORKED EXAMPLE

2-LEG BRIDLE — COMBINED CAPACITY VS ANGLE

SLING ANGLE	PER-LEG FACTOR	2-LEG TOTAL CAPACITY
90°	1.000	2.00 × single WLL
60°	0.866	1.73 × single WLL
45°	0.707	1.41 × single WLL
30°	0.500	1.00 × single WLL — no benefit over one leg

READ THE ANGLE, THEN THE TABLE

Find the sling's angle from the horizontal (use a smartphone angle app or a simple plumb line). Look up the factor, multiply by the single-leg WLL from the spec table, and you have the rated capacity of each leg.

90°

ANGLE FOR FULL CAPACITY

30°

ABSOLUTE MINIMUM ANGLE

0.75×

CHOKER CAPACITY FACTOR

Two-leg capacity peaks near the vertical and falls away fast — a pair of legs at 30° from horizontal carries no more than a single vertical leg, while adding large inward crushing forces on the load. Read the angle, apply the factor, and keep the included angle tight every time.

01 — SLING ENGINEERING

HOW RATED CAPACITY IS CALCULATED

Rated capacity — also called rated load or WLL — is built from the rope’s breaking force, the number of legs, the sling angle, a design factor and the efficiency of the splice. The same equation runs through every table in this handbook.

$$RC = (MBF \times L \times \sin A) \div DF \times NSE$$

WHAT EACH TERM MEANS

- ◆ RC — Rated Capacity, in tons
- ◆ MBF — Minimum Breaking Force of the rope, in tons
- ◆ L — Number of sling legs
- ◆ Sin A — Sine of the smallest horizontal sling angle
- ◆ DF — Design Factor (safety factor)
- ◆ NSE — Nominal Splice Efficiency
- ◆ CF — Choke Factor (choker hitch only)

DESIGN FACTOR (DF)

The design factor — formerly the “safety factor” — is the number the breaking force is divided by. For wire rope slings it is 5 : 1. It is an allowance for wear, shock and the unexpected, and must never be consumed in normal lifting.

APPLICATION	DESIGN FACTOR
Wire rope sling	5 : 1
Cable laid sling	5 : 1
Poured socket (sling use)	5 : 1
Poured socket (boom support)	3 : 1
Polyester sling	7 : 1

For a choker hitch, replace NSE with the Choke Factor (CF) and use the choker rated-capacity equation. Choker rated capacity does not apply to multi-part slings — see the multi-part equations in the manual.

USING THE EQUATION SAFELY

DO

- ✓ Use the smallest horizontal sling angle in the calculation.
- ✓ Divide the breaking force by the full design factor — every time.
- ✓ Match the splice efficiency (NSE) to the actual termination.
- ✓ Round the rated capacity DOWN to the next whole tonne.

DON'T

- ✗ Never calculate on the rope’s breaking force directly.
- ✗ Never spend the design factor to “make it fit”.
- ✗ Never apply a choker factor to a multi-part sling.
- ✗ Never mix metric and imperial inside one calculation.

SANITY-CHECK EVERY NUMBER

THE TWO-MINUTE CHECK

Before any calculated capacity is trusted, confirm four inputs — the rope grade and class, the actual termination and its NSE, the number of legs truly sharing the load, and the smallest horizontal angle in the bridle. Get those right and the equation does the rest.

5:1

WIRE-ROPE
SLING DF

7:1

POLYESTER
SLING DF

10:1

ELEVATOR
ROPE DF

01 — SLING ENGINEERING

RATED CAPACITY — WORKED EXAMPLES

Three calculations for a 1" 6×19 EIPS IWRC sling: MBF = 51.7 tons, DF = 5, NSE = 0.95. Same equation, three hitches.

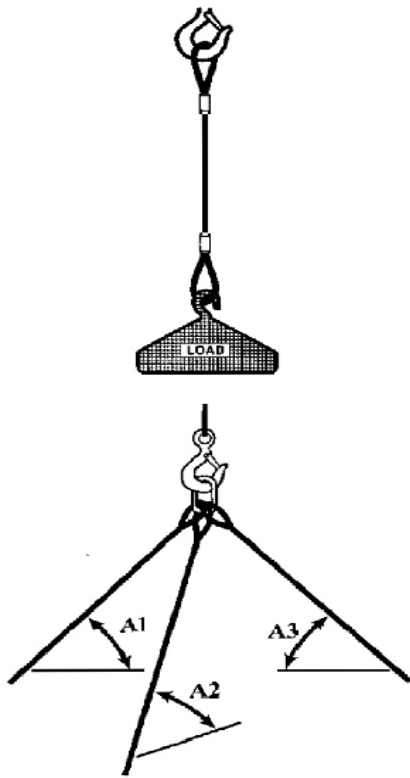

SINGLE-LEG VERTICAL (FIG. 6) AND 3-LEG BRIDLE (FIG. 7)

Always use the smallest horizontal angle in a bridle — and the leg carrying that angle — to find the minimum required sling size. Rated capacities round to whole numbers at and above 10 tons.

WORKED CAPACITIES — SAME ROPE, DIFFERENT RIGGING

CONFIGURATION	WLL (TONNES)	CALCULATION
Single leg, vertical	9.8	$51.7 \div 5 \times 0.95$
Choker hitch (straight)	7.4	Single WLL \times 0.75
Vertical basket	19.6	Single WLL \times 2.0
2-leg bridle @ 60° (per leg)	8.5	Single WLL \times sin 60°
2-leg bridle @ 45° (per leg)	6.9	Single WLL \times sin 45°
3-leg bridle, 45° smallest	20.8	$3 \times 9.8 \times \sin 45^\circ$

1
SINGLE LEG VERTICAL
 $RC = (51.7 \times 1 \times 1) \div 5 \times 0.95 = 9.8$ tons. L = 1, A = 90°, Sin A = 1.

2
VERTICAL BASKET
 $RC = (51.7 \times 2 \times 1) \div 5 \times 0.95 = 19.6 \rightarrow 20$ tons. L = 2, A = 90°.

3
3-LEG BRIDLE (45° SMALLEST)
 $RC = (51.7 \times 3 \times 0.707) \div 5 \times 0.95 = 20.8 \rightarrow 21$ tons.
 Smallest angle A1 = 45°, Sin A1 = 0.707.

ALWAYS SIZE UP, NEVER DOWN
 When a calculated capacity lands between two sling sizes, choose the larger — rounding down quietly consumes the design factor.

- CONFIRM BEFORE CALCULATING**
- ◆ Rope grade (IPS / EIPS / EEIPS) and class (6×19 / 6×36).
 - ◆ Termination type — mechanical NSE ≈ 0.95, hand-tucked 0.80–0.90.
 - ◆ Number of legs actually sharing the load.
 - ◆ The smallest horizontal angle in the bridle.

01 — SLING ENGINEERING

SPLICE & TERMINATION EFFICIENCY

No splice is 100% of the rope. Nominal Splice Efficiency (NSE) is the ratio of the spliced termination’s breaking strength to the rope’s minimum breaking force — and it depends on how the eye is made and how big the rope is.

TABLE 3 — HAND TUCKED (6*19 & 6*36)

ROPE DIA.	HAND TUCKED
1/4"	0.90
5/16"	0.89
3/8"	0.88
7/16"	0.87
1/2"	0.86
9/16"	0.85
5/8"	0.84
11/16"	0.83
3/4"	0.82
7/8"	0.81
1"	0.80
1-1/8"	0.80
1-1/4"	0.80
1-1/2" & up	0.80

TABLE 4 — MECHANICAL (IPS / EIPS)

ROPE DIA.	IWRC	FIBER
1/4"	0.95	0.925
3/8"	0.95	0.925
1/2"	0.95	0.925
5/8"	0.95	0.925
3/4"	0.95	0.925
7/8"	0.95	0.925
1"	0.95	0.925
1-1/8"	0.925	0.90
1-1/4"	0.925	0.90
1-1/2"	0.925	0.90
1-3/4"	0.925	0.90
2"	0.925	0.90
2-1/8" & up	0.90	—

Cable-laid mechanical: 0.95 (≤1"), 0.925 (above). Braided multi-part: 0.70. Zinc / resin poured sockets: 100%.

WHY MECHANICAL BEATS HAND TUCKED

A mechanical (Flemish eye) splice keeps the core working through the eye, so it carries more of the rope’s strength than a hand tucked splice — which cuts the core in the splice area. That is why mechanical NSE runs ~0.95 against ~0.80–0.90 hand tucked.

Splice efficiency multiplies into every rated-capacity calculation — a 0.80 hand-tucked eye gives up a fifth of the rope before the lift even begins. Always read NSE from the table that matches the actual termination and rope size.

100% POURED SOCKET	~0.95 MECHANICAL SPLICE	0.80–0.90 HAND-TUCKED EYE	0.70 BRAIDED MULTI-PART
------------------------------	-----------------------------------	-------------------------------------	-----------------------------------

PUTTING NSE TO WORK

MATCH THE TABLE TO THE TERMINATION

NSE is not one number — it changes with both the splice type and the rope diameter. Read the efficiency from the row that matches the actual eye, multiply it into the rated-capacity equation, and never borrow a mechanical-splice figure for a hand-tucked eye.

EFFICIENCY, LARGEST TO SMALLEST

- ◆ Zinc / resin poured socket — 100%.
- ◆ Swaged Flemish mechanical splice — ~95%.
- ◆ Hand-tucked eye — 0.80–0.90 by diameter.
- ◆ Braided multi-part sling — ~0.70.
- ◆ Wire-rope clips — standing rigging only, not slings.

01 — SLING ENGINEERING

TERMINATIONS & END FITTINGS

How the eye is formed decides the sling’s strength, its inspectability and its cost. Four families cover almost every wire-rope sling we build.

HAND TUCKED SPLICE

The dead end is tucked back into the body — one forming tuck and three or four full tucks. Flexible and easy to inspect; efficiency 0.80–0.90 by diameter.

MECHANICAL SPLICE

Returned loop or Flemish eye, secured with pressed (swaged) metal sleeves. Higher efficiency (~0.95) and the most common production splice.

ZINC / RESIN POURED SOCKET

Wires are broomed, cleaned, fluxed and the socket basket filled with zinc or resin. 100% efficient — the benchmark every other termination is measured against.

THIMBLE-PROTECTED EYE

A thimble protects the rope in the eye against the pin. Eyes run ~8 body diameters wide × 16 long; thimbles are recommended wherever possible.

TERMINATION EFFICIENCY & PROOF LOAD

TERMINATION TYPE	EFFICIENCY	PROOF TEST	REMARKS
Poured Socket — Zinc	100%	2 × WLL	Benchmark; factory only
Poured Socket — Resin	100%	2 × WLL	Field-pour resin systems
Swaged Sleeve (Flemish)	95–100%	2 × WLL	Most common; fully mechanical
Mechanical Splice	90–95%	2 × WLL	Flemish eye + 2 pressed sleeves
Hand Tucked Splice	80–90%	1.25 × WLL	≥ 4 full tucks required
Wire Rope Clip	≤ 80%	Not for slings	Standing rigging only

STANDARD EYE DIMENSIONS · W = 8D · L = 16D

ROPE D (MM)	D (IN)	EYE WIDTH W	EYE LENGTH L	MIN PIN Ø
8	5/16	64 mm	128 mm	10 mm
10	3/8	80 mm	160 mm	12 mm
13	1/2	104 mm	208 mm	16 mm
16	5/8	128 mm	256 mm	19 mm
19	3/4	152 mm	304 mm	22 mm
22	7/8	176 mm	352 mm	25 mm
26	1	208 mm	416 mm	30 mm
32	1-1/4	256 mm	512 mm	37 mm
38	1-1/2	304 mm	608 mm	44 mm

Per ASME B30.9. Min pin Ø ≥ body diameter. Thimbles recommended on all pin-bearing eyes.

PROOF LOAD & PIN DIAMETER

Mechanical-splice slings proof-loaded to 2× vertical WLL; hand tucked slings to 1.25×. ASME B30.9 requires proof testing on all swaged and poured-socket assemblies. Max pin diameter = (2L + W) × 0.2 — never smaller than the sling body diameter. Proof-test certificates must be retained for the life of the sling.

SLEEVE & SOCKET REQUIREMENTS

- ◆ Sleeve material: copper (bright) or aluminium alloy.
- ◆ Press in a calibrated die set — never a bench vice.
- ◆ Minimum 2 sleeves for rope ≥ 16 mm diameter.
- ◆ Proof-test every assembly at 2 × WLL after pressing.
- ◆ Resin sockets: observe mix ratio & full cure time.
- ◆ Mark with press operator's ID after inspection.
- ◆ Never re-use a sleeve that has been pressed once.

01 — SLING ENGINEERING

STEEL GRADE — MORE STRENGTH, SAME DIAMETER

Tensile grade is stamped on the certificate, not the rope. Two ropes of identical diameter and construction can carry very different loads depending on grade. Stepping up one grade gives more capacity without changing the rope size.

TENSILE GRADE COMPARISON — SAME DIAMETER, MORE STRENGTH

GRADE (N/MM ²)	AMERICAN NAME	VS IPS STRENGTH	BEST FOR
1420 TS	Traction Steel	-20%	Light traction, aerial tramways
1570 PS	Plow Steel	-10%	General mining, guy strand
1770 IPS	Improved Plow Steel	Baseline	General lifting — the catalog standard
1960 EIPS	Extra Improved Plow Steel	+10%	Heavy lifting, mobile cranes
2160 EEIPS	Extra Extra Improved	+22%	Critical lifts, offshore, tall hoists

UPGRADE GRADE, NOT DIAMETER

If you need more capacity without a heavier rope, step up one tensile grade. EIPS gives 10% more breaking force than IPS at the same diameter — saving weight on tall hoists where every kilogram of rope counts.

GRADE SUMMARY

- ◆ IPS (1770 N/mm²) — standard crane and hoist work.
- ◆ EIPS (1960 N/mm²) — mobile cranes, offshore hoists.
- ◆ EEIPS (2160 N/mm²) — critical lifts, tall hoists.
- ◆ Galvanized — marine and coastal environments.
- ◆ Grade comes from the certificate, not the rope’s appearance.

Grade determines breaking force. Always confirm grade from the mill certificate. Two ropes that look identical can differ by one full tensile grade — and 22% of breaking force.

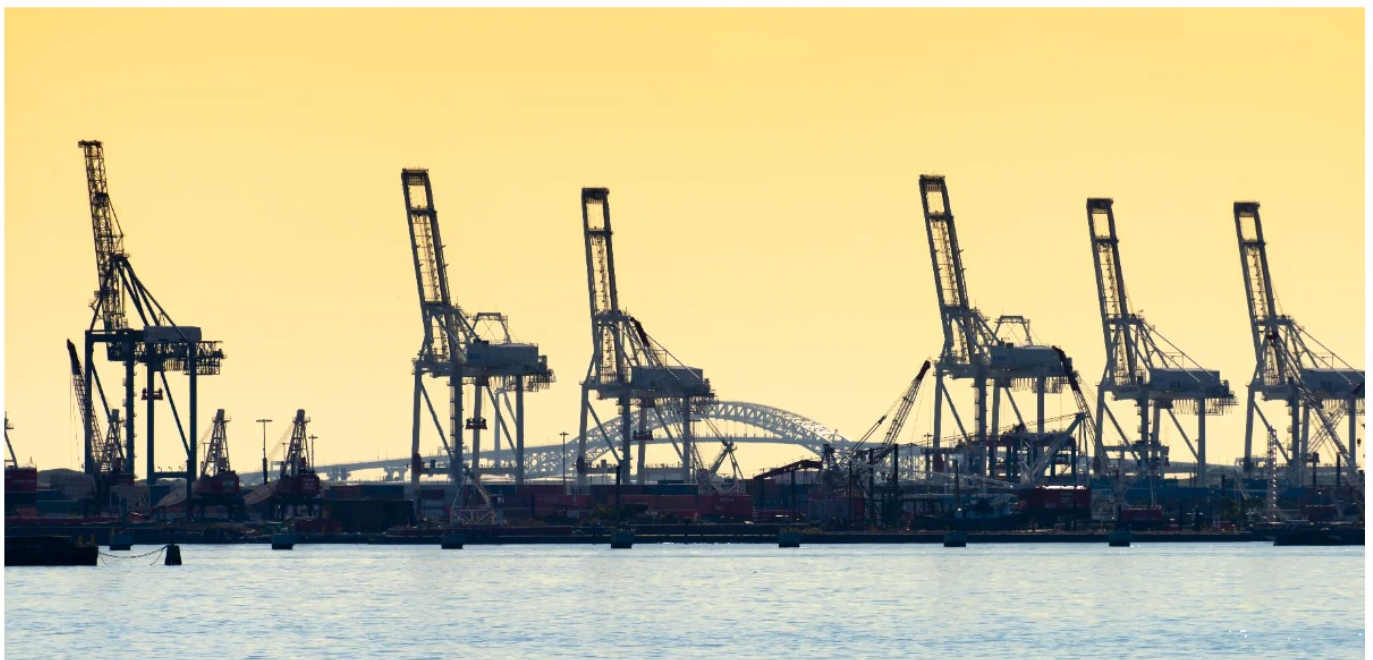

01 — SLING ENGINEERING

STRENGTH & WEIGHT REFERENCE

Minimum breaking force and approximate weight for bright (uncoated) 6×19 and 6×36 class wire rope, IWRC. Common sling diameters; capacities in tons of 2,000 lb.

DIA. (IN)	DIA. (MM)	WEIGHT (LB/FT)	IPS (TONS)	EIPS (TONS)	EEIPS (TONS)
1/4	6	0.12	2.94	3.40	—
5/16	8	0.18	4.58	5.27	5.80
3/8	9	0.26	6.56	7.55	8.30
7/16	11	0.35	8.89	10.2	11.2
1/2	13	0.46	11.5	13.3	14.6
9/16	14	0.59	14.5	16.8	18.5
5/8	16	0.72	17.7	20.6	22.7
3/4	19	1.04	25.6	29.4	32.4
7/8	22	1.39	34.6	39.8	43.8
1	26	1.85	44.9	51.7	56.9
1-1/8	28	2.34	56.5	65.0	71.5
1-1/4	32	2.89	69.4	79.9	87.9
1-3/8	35	3.49	83.5	96.0	106.0
1-1/2	38	4.16	98.9	114.0	125.0
1-5/8	41	4.89	115.0	132.0	145.0
1-3/4	44	5.67	132.0	153.0	168.0
1-7/8	48	6.50	150.0	174.0	191.0
2	50	7.40	170.0	196.0	216.0
2-1/8	54	8.35	190.0	220.0	242.0
2-1/4	57	9.37	212.0	244.0	268.0

WRTB minimum breaking force, 6×19 / 6×36 class, bright, IWRC. Drawn-galvanized rope is available at ~10% lower strength. EEIPS not produced below 5/16". To convert tons to kN, multiply by 8.896.

READING THE TABLE

THESE ARE BREAKING FORCES — NOT WORKING LOADS

Every figure here is the minimum breaking force of new rope. To get a working load limit, divide by the design factor (5:1 for wire-rope slings), then apply the hitch and angle factors. Never lift on a breaking-force number.

QUICK CONVERSIONS

- ◆ Tons → kN: multiply by 8.896.
- ◆ Drawn-galvanized rope: ≈ 10% lower strength.
- ◆ IWRC core: ≈ 7½% of the breaking force.
- ◆ Figures are 6×19 / 6×36 class, bright, IWRC.

01 — SLING ENGINEERING

WHEN TO REMOVE A SLING FROM SERVICE

ASME B30.9 requires a wire-rope sling to be removed from service immediately if any of the following is present. The goal of inspection is to judge the strength remaining in a sling that has already been used.

- | | |
|---|--|
| <p>1</p> <p>BROKEN WIRES</p> <p>Single-part slings & strand-laid grommets: 10 randomly distributed broken wires in one rope lay, or 5 in one strand in one lay. Cable laid: 20 per lay. Braid under 8-part: 20 per braid; 8-part or more: 40.</p> | <p>2</p> <p>DISTORTION</p> <p>Kinking, crushing, birdcaging or any damage that distorts the rope structure or pushes wires and strands out of position.</p> |
| <p>3</p> <p>HEAT DAMAGE</p> <p>Metallic discoloration, fusing of wires, or loss of internal lubricant caused by exposure to heat.</p> | <p>4</p> <p>DAMAGED END ATTACHMENTS</p> <p>Cracked, bent or broken end fittings caused by abuse, wear or damage.</p> |
| <p>5</p> <p>BENT HOOKS</p> <p>More than 5% over the normal throat opening, measured at the narrowest point (per ASME B30.10).</p> | <p>6</p> <p>CORROSION</p> <p>Severe corrosion of the rope or end attachments causing pitting or binding of wires. Light surface rust does not substantially affect strength.</p> |
| <p>7</p> <p>PULLED EYE SPLICES</p> <p>Any sign that an eye splice has slipped, that tucked strands have moved, or that pressed sleeves are seriously damaged.</p> | <p>8</p> <p>UNBALANCE</p> <p>A kink from pulling a loop through under load deforms wires and strands, unbalancing the sling and reducing strength.</p> |

TAG IT “DO NOT USE”

When a sling is worn out or damaged beyond use, tag it DO NOT USE immediately and destroy it — cut the eye and fittings off with a torch — so no one mistakes it for a serviceable sling.

10	5	20	7-10%
BROKEN WIRES / LAY — SINGLE PART	BROKEN WIRES / STRAND / LAY	CABLE-LAID — PER LAY	MAX DIAMETER REDUCTION

Per ASME B30.9. Any one of the eight conditions above is enough to retire the sling — the limits are not cumulative, and a sling that reaches any of them must be removed the same day, not at the next periodic inspection.

01 — SLING ENGINEERING

INSPECTION INTERVALS & METHOD

ASME B30.9 and OSHA require two kinds of inspection — a frequent visual check, and an additional periodic inspection by a designated, qualified person, with written records.

FREQUENT (DAILY) VISUAL

Performed by the person using the sling, each day it is used. Look for obvious broken wires, kinks, crushing, broken attachments and severe corrosion.

PERIODIC

At intervals based on frequency of use, severity of service, nature of the lifts and prior experience. Carried out by a designated person who knows wire rope, and recorded in writing and dated.

HOW TO INSPECT — SYSTEMATIC STEPS

- ◆ Lay the sling out so every part is accessible.
- ◆ Clean off dirt and grease so wires and fittings show.
- ◆ Examine the full length; watch the most-worn sections.
- ◆ Pay special attention to fittings and end attachments.
- ◆ Check the worst section against the removal criteria.
- ◆ Label or identify slings that have been inspected.
- ◆ Keep dated records with the conditions found.
- ◆ Dispose of rejected slings immediately.

A good inspection program is worthless if worn-out slings are not actually destroyed. Proper, orderly storage out of the weather makes every inspection faster and more thorough.

WHAT A GOOD PROGRAM LOOKS LIKE

TWO INSPECTIONS, ONE RECORD

A daily visual by the user catches gross damage; a dated periodic inspection by a competent person catches what the eye misses. Neither is optional — and the written record is what makes the program auditable.

SET THE PERIODIC INTERVAL BY

- ◆ Frequency of use.
- ◆ Severity of the service and environment.
- ◆ Nature of the lifts and consequence of failure.
- ◆ Experience from the life of similar slings.



01 — SLING ENGINEERING

STORAGE & CARE

Temperature, lubrication and moisture decide how long a sling lasts. A little care between lifts adds up to a much longer, safer service life.

<p>STORAGE</p> <p>Keep slings on a rack, away from water, heat, corrosive fumes and sprays. Never leave a sling under a load or lying where it can be run over or kinked.</p>	<p>LUBRICATION</p> <p>Wire rope is lubricated when made. If a sling is stored outside or in a corrosive environment, re-lubricate with the same type of lubricant to prevent rust.</p>	<p>HANDLING</p> <p>A rack lets larger slings be lifted by crane — less manhandling, less accidental damage, and easier condition monitoring between inspections.</p>
--	---	---

TEMPERATURE LIMITS

CORE TYPE	MAXIMUM	MINIMUM
Fiber core sling	180°F (82°C)	—
Steel core (IWRC) sling	400°F (204°C)	-40°F (-40°C)

Heat damage is hard to detect — the common signs are loss of lubrication and discoloration or fusing of wires. If a sling may have been overheated, take it out of service.

CARE BETWEEN LIFTS

DO

- ✓ Hang slings on a rack, clear of the floor.
- ✓ Re-lubricate rope stored outdoors or in damp air.
- ✓ Keep slings out of weather, fumes and direct heat.
- ✓ Tag and isolate any sling awaiting inspection.

DON'T

- ✗ Never leave a sling under a parked load.
- ✗ Never store on a wet or contaminated floor.
- ✗ Never drag rope through grit, acid or alkali.
- ✗ Never coil a sling so tight that it kinks.

RE-LUBRICATION & SERVICE LIFE

LUBRICANT IS PART OF THE ROPE

A wire rope is lubricated when it is made, and that lubricant keeps the wires sliding and the steel from rusting. Wash-down, weather and age strip it away — re-apply a compatible lubricant to clean, dry rope and a sling can outlast an un-maintained one several times over.

BEFORE A SLING GOES ON THE RACK

- ◆ Wipe off grit, mud and chemical splash.
- ◆ Dry the rope — never store it wet.
- ◆ Re-lubricate if it has been washed or looks dull.
- ◆ Check the tag is present and legible.
- ◆ Coil to a generous diameter — never tight enough to kink.
- ◆ Hang it clear of the floor, weather and fumes.

<p>82°C</p> <p>MAX — FIBRE-CORE SLING</p>	<p>204°C</p> <p>MAX — IWRC STEEL-CORE SLING</p>	<p>-40°C</p> <p>MIN — STEEL-CORE SLING</p>
--	--	---

01 — SLING ENGINEERING

THINGS EVERY USER SHOULD KNOW

A brief outline of the basics required to use wire rope and wire rope slings safely. It is not a complete discussion — read the manufacturer’s literature and the applicable standards.

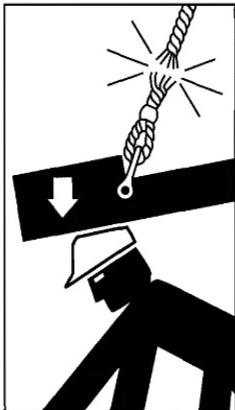

⚠ WARNING

Wire Rope **WILL FAIL** if worn-out, overloaded, misused, damaged, improperly maintained or abused. Wire rope failure may cause serious injury or death!

Protect yourself and others:

- ALWAYS INSPECT wire rope for WEAR, DAMAGE or ABUSE BEFORE USE.
- NEVER USE wire rope that is WORN-OUT, DAMAGED or ABUSED.
- NEVER OVERLOAD a wire rope.
- INFORM YOURSELF: Read and understand manufacturer's literature or "Wire Rope and Wire Rope Sling Safety Bulletin".*
- REFER TO APPLICABLE CODES, STANDARDS and REGULATIONS for INSPECTION REQUIREMENTS and REMOVAL CRITERIA.*

* For additional information or the BULLETIN, ask your employer or wire rope supplier.

© 1993, Wire Rope Technical Board Form No. 193

WIRE ROPE & WIRE ROPE SLING SAFETY BULLETIN

IF IN DOUBT, REPLACE THE ROPE

Published breaking force applies only to a new, unused rope. Wire ropes wear out — strength begins to drop the moment a rope goes into service.

THE ESSENTIALS

- ◆ Wire rope **WILL** fail if worn out, overloaded, misused, damaged or improperly maintained.
- ◆ Minimum Breaking Force applies only to new rope — it is never the working load.
- ◆ Reduce MBF by the Design Factor to get the working load; you choose the factor.
- ◆ Never overload, and never “shock load” — sudden force can damage rope invisibly.
- ◆ Inspections and signed permanent records are required by OSHA for almost every installation.
- ◆ A sling removed from service must never be re-used on another application.
- ◆ Sheaves and pins that are too small damage rope; pad sharp bends.
- ◆ Kinks permanently damage rope; ropes with knots must never be used.
- ◆ Protect the sling body from sharp edges and corners with padding or blocking.

WHEN IN DOUBT, TAKE IT OUT

No lift is worth a life. If a sling’s condition, capacity or certificate is in any doubt, take it out of service and have it inspected — a replacement sling costs a fraction of the load, the machine, or the person beneath it.

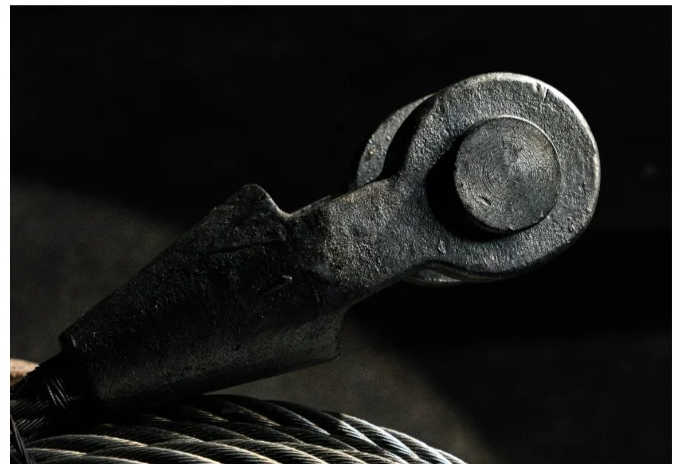
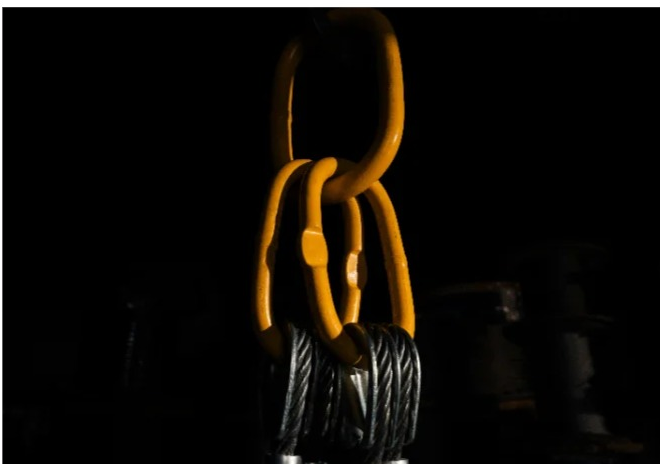

01 — SLING ENGINEERING

GLOSSARY OF KEY TERMS

A - L

- ◆ Aggregate Strength — sum of the breaking strengths of every wire; ignores angularity losses.
- ◆ Bending Stress — stress imposed on wires by bending or curving the rope.
- ◆ Birdcage — wires forced into a cage shape by compression; cause for removal.
- ◆ Body Diameter — diameter of the smallest circle around the sling body.
- ◆ Breaking Force — the load at which a sample fails in tension.
- ◆ Design Factor — breaking force ÷ working load; the safety allowance.
- ◆ D/d Ratio — bend diameter (D) ÷ rope diameter (d).
- ◆ IWRC — Independent Wire Rope Core; ~7½% of MBF.
- ◆ Lay — direction and length the wires and strands are laid.

M - Z

- ◆ Minimum Breaking Force (MBF) — published catalog strength of new rope.
- ◆ Nominal Splice Efficiency (NSE) — spliced strength ÷ rope MBF.
- ◆ Proof Load — non-destructive test load applied to verify a finished sling.
- ◆ Rated Capacity (RC) — maximum static load a sling may lift; = rated load = WLL.
- ◆ Reeving — passing rope through sheaves or fittings.
- ◆ Serving — wrapping wire around a splice or rope end.
- ◆ Sling Angle — angle of a leg measured from the horizontal plane.
- ◆ Strand — wires laid helically around a center.
- ◆ Swage — to press a metal sleeve onto rope to form a mechanical splice.

Definitions condensed from the WRTB Wire Rope Sling Users Manual glossary. For full definitions and the complete rated-capacity tables, consult the manual or KCB engineering.

ABBREVIATIONS AT A GLANCE

ROPE & CORE

- ◆ FC — Fibre Core
- ◆ IWRC — Independent Wire Rope Core
- ◆ WSC — Wire Strand Core
- ◆ RHOL — Right-Hand Ordinary Lay

STRENGTH & TEST

- ◆ MBF — Minimum Breaking Force
- ◆ WLL / RC — Working Load Limit / Rated Capacity
- ◆ NSE — Nominal Splice Efficiency
- ◆ DF — Design Factor (safety factor)

SPEAK THE LANGUAGE, READ THE TAG

Every term here turns up on a sling tag, a mill certificate or a rated-capacity table. Knowing that “6×36WS IWRC RHOL 1960” means a 36-wire Warrington-Seale rope on a steel core, right-hand ordinary lay, EIPS grade — is the difference between guessing and engineering the lift.

÷ **DF**

MBF → WLL

6-8d

ONE ROPE LAY LENGTH

× **0.95**

MECHANICAL-SPLICE NSE



02

WIRE ROPE SLING

Strength forged from steel — from mining hoists to tower-crane main lines.

COMPACT WIRE ROPE SLING

STANDARD WIRE ROPE SLING

6×36 / 6×19

8-STRAND

LOW-ROTATION

API 9A · EN 12385-4

02 — WIRE ROPE SLING

A ROPE IS A MACHINE

By every engineering definition, a wire rope is a machine. Hundreds of individual high-carbon steel wires are drawn cold to precise diameters, laid helically into strands, then laid again around a core. When the rope bends around a sheave, every wire slides past its neighbours to accommodate the length difference. The sharper the bend, the greater the relative motion — and the more critical correct rope selection becomes.

THREE CORE COMPONENTS

01

WIRES

High-carbon steel drawn cold to precise diameter. Strength, fatigue resistance and corrosion behaviour all depend on tensile grade and surface treatment.

02

STRANDS

Wires laid helically around the core. Strand pattern — Seale, Warrington, Filler or WS — governs abrasion and bending-fatigue behaviour.

03

CORE

FC (fibre) is more flexible; IWRC resists crushing and supports higher loads; WSC is used in rotation-resistant constructions.

Tensile grade defines the breaking strength of the finished rope. Higher grades (EIPS, EEIPS) deliver more capacity for the same diameter — preferred where headroom or rope weight is constrained.



sZ Or RHRL
Right Regular Lay



zS Or LHRL
Left Regular Lay



zZ Or RHLL
Right Langs Lay



sS Or LHLL
Left Langs Lay

IMAGE ABOUT LAY DIRECTION OR WIRE ROPE SLING

02 — WIRE ROPE SLING

CONSTRUCTION, CLASS & GRADE

Match the construction to the duty. KCB Sling supplies a full spectrum of wire-rope classes from 1.0 mm to 64 mm diameter — round-strand, compacted (Powerform), rotation-resistant, galvanized, ungalvanized, PVC-coated and combination ropes — all to BS EN 12385-4, JIS G 3525 and API 9A.

CLASS	CONSTRUCTIONS	CHARACTER	BEST FOR
6×19 Class	6×26WS, 6×25F, 6×19S, 6×19W	Good abrasion + fatigue balance	General crane, lattice boom
6×36 Class	6×36WS, 6×31WS, 6×29F	Superior bending-fatigue life	Container crane, ladle, mooring
8×19 / 8×36	8×36WS, 8×25F, 8×19S	Large surface contact, flexible	Container hoist, boom, trolley
Compacted (Powerform)	6×K / 8×K compacted strands	Higher BL, crush & wear resist	Mobile crane, multi-layer drum
Rotation-Resistant	18×7, 18×19S, 35×7	Anti-spin under free load	Tower crane, tall single-fall lifts
Small / Multi-Strand	6×7, 7×7, 6×19M	Stable, kink-resistant	Sand line, guy, control, fishing

COMPACTION — POWERFORM™

A patented compaction process flattens the outer strand surface, increasing steel area and metallic contact. The result: higher breaking load, greater crushing resistance and longer fatigue life than equivalent round-strand rope — ideal for multi-layer spooling on crane main hoists.

GALVANIZING & FINISH

Bright (ungalvanized), galvanized, drawn-galvanized and stainless 304/316 finishes are available. Zinc and Zn-Al coatings protect against corrosion in marine, offshore and humid environments.

CORE TYPES

- ◆ FC — Fibre Core. More flexible, lighter; for lower-load and hand-spliced service.
- ◆ IWRC — Independent Wire Rope Core. Resists crushing, supports higher working loads.
- ◆ WSC — Wire Strand Core. Used inside rotation-resistant and compacted constructions.

LAY DIRECTION

- ◆ Regular Lay (RH/LH). Wires lie opposite to strands — stable, kink-resistant, easy to handle.
- ◆ Lang's Lay. Wires parallel to strands — best abrasion & fatigue life on guided drums.

02 — WIRE ROPE SLING

WIRE ROPE CONSTRUCTIONS

Construction is the language of wire rope. The first number is the count of strands laid around the core; the second is the number of wires in each strand. More strands and finer wires give flexibility and fatigue life; fewer, heavier wires give abrasion resistance. These scale cross-sections cover the full range we supply.

CONSTRUCTIONS WE SUPPLY

6×7	6×19	6×36	6×37	6×5(19)	6×W(19)	6×FI(25)	6×W5(26)	6×W5(31)	6×W5(36)	8×5(19)
8×W(19)	8×FI(25)	18×7	19×7	35×7	7×7	7×19	1×7	1×19		

S = Seale · W = Warrington · Fi = Filler · WS = Warrington-Seale. Cores: FC fibre core, IWRC independent wire rope core (shown with an orange centre wire). Diagrams are to scale within each tile and are for identification; refer to the spec tables for dimensions and breaking loads.

CORES WE SUPPLY

FC — FIBRE CORE	IWRC — INDEPENDENT WIRE ROPE CORE	WSC — WIRE STRAND CORE
-----------------	-----------------------------------	------------------------

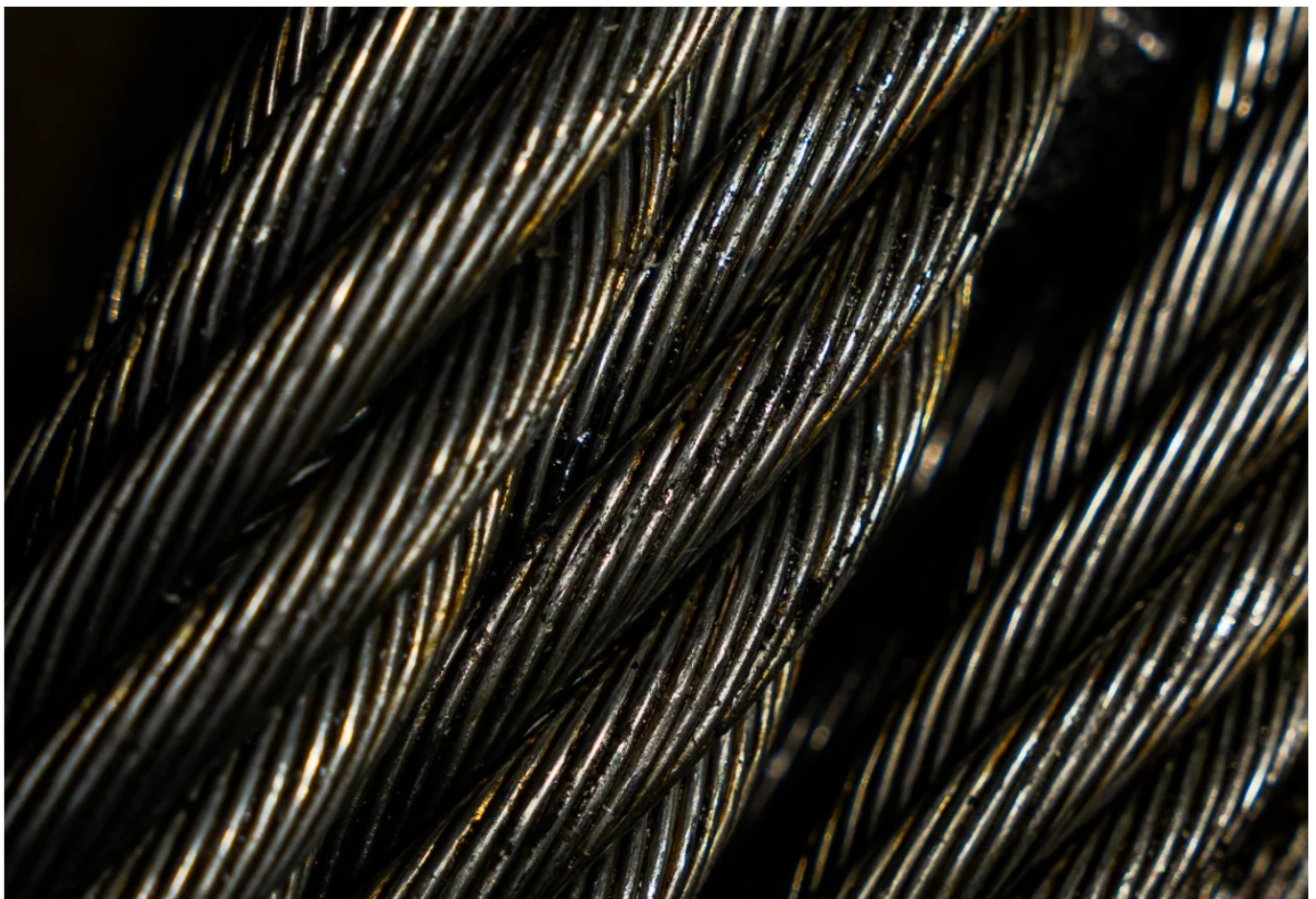

02 — WIRE ROPE SLING

STRAND CONSTRUCTION & LAY DIRECTION

Inside every strand the wires are laid in a repeating pattern; the strands themselves are then laid around the core in a chosen direction and pitch. Pattern and lay together decide how a rope balances strength, flexibility, abrasion and rotation. Equal-lay strands (Seale, Warrington, Filler) keep linear contact between wires for longer life; cross-lay strands cross over each other.

STRAND CONSTRUCTION — EQUAL-LAY PATTERNS

<p>SEALE 9 + 9 + 1</p>	<p>WARRINGTON 6 / 6 + 6 + 1</p>	<p>FILLER 12 + 6F + 6 + 1</p>	<p>WARRINGTON-SEALE WS — multi-layer</p>
-----------------------------------	--	--	---

LAY DIRECTION — STRAND VS WIRE

<p>SZ / RRL Right Regular Lay</p>	<p>ZS / LRL Left Regular Lay</p>	<p>ZZ / RLL Right Lang Lay</p>	<p>SS / LLL Left Lang Lay</p>
--	---	---	--

Regular lay: wires run opposite to the strand lay, giving a stable, abrasion-resistant, easy-handling rope — the default for slings and general lifting. Lang lay: wires run the same way as the strand, giving better fatigue and wear life on sheaves but it must be both ends fixed against rotation. Right lay is the standard direction unless the machine demands left lay.

CHOOSING PATTERN & LAY

REGULAR LAY IS THE DEFAULT

For slings and general lifting, right regular lay is the safe default — it resists kinking, handles easily and will not tend to spin. Reserve Lang lay for guided, both-ends-fixed machine reeving where its longer fatigue and wear life can be used safely.

PATTERN AT A GLANCE

- ◆ Seale (S) — large outer wires, best abrasion resistance.
- ◆ Warrington (W) — alternating wire sizes, balanced.
- ◆ Filler (Fi) — small filler wires, smooth & flexible.
- ◆ Warrington-Seale (WS) — multi-layer, longest fatigue life.

02 — WIRE ROPE SLING

SHEAVE, DRUM & D/D RATIO

Every time a rope bends over a sheave or drum it loses a little life. The ratio of sheave tread diameter D to rope diameter d is the single biggest lever on fatigue life. Recommended sheave diameter = rope diameter × the factor below. Reducing a sheave from 40d to 20d can cut rope life by up to 90%.

SUGGESTED D/D — SHEAVES & DRUMS

CONSTRUCTION	SUGGESTED	MINIMUM
6×7	72	42
6×19S · 19×7 · 18×7	51	34
6×21FW · 6×25B · 6×26WS	45	30
6×31WS · 6×36WS	35	23
6×37 · 8×19	31	21
6×41 · 6×49	26	18

D = sheave tread diameter, d = rope diameter. ASME B30.5 permits a minimum hoist D/d of 18 and boom-hoist D/d of 15. Higher rope speed needs a larger sheave.

SLING D/D — CAPACITY REDUCTION

OBJECT ÷ ROPE D/D	EFFICIENCY	ACTION
25 d or larger	100%	Full rated capacity
10 d	≈ 92%	Light reduction
5 d	≈ 75%	Reduce capacity ~25%
2 d	≈ 60%	Reduce capacity ~40%
1 d	≈ 50%	Reduce capacity ~50%

GROOVE GEOMETRY

Groove radius 0.53–0.55 × d (about 1% over rope diameter); groove depth ≈ 1.5 × d. Sheave surface hardness min 35 RC, better 40–45 RC. Keep the fleet angle within ~1.5° (grooved) to 2° (plain). Use grooved drums; for more than 3 layers use Lebus grooving.

DO

- ✓ Match sheave & drum diameter to the rope construction.
- ✓ Wind top-to-top / bottom-to-bottom to avoid reverse bends.
- ✓ Keep the basket / choker D/d ratio generous.

DON'T

- ✗ Run rope over worn, soft or grooved-out sheaves.
- ✗ Reverse-bend the rope between two sheaves.
- ✗ Exceed the fleet angle — it abrades and crushes.

THE CHEAPEST WAY TO DOUBLE ROPE LIFE

Fit a bigger sheave. Going from a D/d of 20 to 40 can lift rope life dramatically for no change in the rope itself — while dropping below the minimum D/d quietly throws most of it away.

<p>18:1</p> <p>MIN HOIST D/D · ASME</p>	<p>~90%</p> <p>LIFE LOST, 40D → 20D</p>	<p>≤1.5°</p> <p>FLEET ANGLE, GROOVED</p>
--	--	---

02 — WIRE ROPE SLING

ROPE SELECTION BY APPLICATION

The right construction for the duty. The list below is a guide where no other guidance exists, or an alternative where one construction has proved unsatisfactory — always confirm with the machine maker and our engineering team for critical lifts. Lay: O = ordinary (regular) lay, L = Lang lay.

SUGGESTED CONSTRUCTION BY APPLICATION

EQUIPMENT	DUTY	STRANDS / CONSTRUCTION	CORE	LAY
CRANES incl. Clamshells	Derrick / Boom	6×19 Fi (6×25Fi) · 6×36	IWRC	O / L
	Hoist (holding / closing)	6×19 Fi · 6×36 · 18×7	IWRC / FC	O / L
	Tag lines	6×19	FC	O
Tower Cranes	Hoist	18×7 · 19×7	FC / Strand	O / L
Dredgers	Boom hoist · Swing	6×19 Fi (6×25Fi)	IWRC	O
	Ladder hoist	6×19 Fi · 6×36	IWRC	O / L
	Spud	6×19 Fi (6×25Fi)	IWRC	O
Drilling (Rotary)	Drilling lines	6×19 Seale	IWRC	O
	Sand / coring / swabbing	6×7 Galv.	Poly	O
	Casing	6×19 Fi (6×25Fi)	IWRC / FC	O
Drilling (Percussion)	Drilling lines	6×21 Fi (usually LH)	FC	O

MUST AVOID FOR LONGER ROPE LIFE

- ◆ Twist, loop or kink of the rope
- ◆ Moisture, dust, acid or sulphuric fumes
- ◆ Overload
- ◆ Crushing or hammering
- ◆ Reverse (S-) bending
- ◆ Too-small sheaves, drums or rollers
- ◆ Hard rolling of sheaves / guide rollers
- ◆ Worn, broken or soft sheaves and rollers
- ◆ Poor or no lubrication
- ◆ Heat influence
- ◆ Excessive fleet angle · vibration
- ◆ Shock — too-fast start or stop

01 — WIRE ROPE SLING

COMPACT WIRE ROPE SLING 35 / 35P

Powerform 35 has the highest strength of all low-rotation hoist ropes, with maximum resistance to rotation. The patented compaction process delivers the highest fatigue life, crushing resistance and abrasion resistance available in a low-rotation construction (35×K7).

KEY FEATURES

- ◆ Highest strength of all low-rotation hoist ropes.
- ◆ Maximum resistance to rotation — single- & multi-part reeving.
- ◆ High fatigue life from the unique compaction process.
- ◆ Increased crushing resistance — multi-layer spooling.
- ◆ Fully lubricated in manufacturing.

TYPICAL APPLICATIONS

- MOBILE CRANE MAIN HOIST
- OFFSHORE PEDESTAL MAIN HOIST
- WHIP HOIST
- MULTI-LAYER DRUM

DIA (MM)	INCH	MASS	BL 1770	BL 1960	BL 2160
13	–	81.3	123	144	155
14	–	94.3	142	180	192
16	5/8	123	186	233	252
18	–	156	235	300	321
19	3/4	174	262	331	358
20	–	192	290	372	399
22	–	233	351	444	484
–	7/8	237	358	453	490
24	–	277	418	531	572

DIA (MM)	INCH	MASS	BL 1770	BL 1960	BL 2160
–	1	310	468	591	640
26	–	325	490	621	661
28	–	377	569	720	788
–	1-1/8	393	593	748	810
32	1-1/4	492	734	944	1035
35	1-3/8	589	884	1125	1216
38	1-1/2	694	1048	1326	1437
40	–	770	1161	1477	1588

Construction 35×K7, steel core. IPS / EIPS / EEIPS grades also available. Figures for guidance only — refer to the works certificate for the as-built minimum breaking force. BL in kN; Mass in kg/100m.

BUILT FOR THE DRUM

Compacted strands give a smooth, hard outer surface that resists crushing on multi-layer drums and holds its round shape under high line pull — the reason Powerform 35 is specified for mobile and offshore main hoists.

SPECIFY WITH

- STEEL CORE (STANDARD)
- IPS / EIPS / EEIPS
- RIGHT OR LEFT LANG LAY
- PRE-LUBRICATED
- CUT TO LENGTH

01 — WIRE ROPE SLING

STANDARD WIRE ROPE SLING 35 / 35P

Hyflex 35/35P is a high-strength flexible hoist rope with anti-spin properties for higher lifts. Very high resistance to rotation — used for taller tower cranes. Lang’s-lay construction (35×7) offers maximum resistance to wear.

KEY FEATURES

- ◆ High-strength flexible hoist rope with anti-spin properties.
- ◆ Very high resistance to rotation — taller tower cranes.
- ◆ Lang’s-lay for maximum wear resistance.
- ◆ Batch-tested to confirm breaking-force compliance.
- ◆ Steel-core; FC available on request.

TYPICAL APPLICATIONS

- MOBILE MAIN HOIST
- TOWER CRANE MAIN HOIST
- OFFSHORE PEDESTAL
- WHIP HOIST

DIA (MM)	INCH	MASS	BL 1770	BL 1960	BL 2160
13	–	72.5	108	119	128
14	–	84.1	125	148	168
16	5/8	110	163	194	221
18	–	139	206	229	245
19	–	155	230	255	273
19	3/4	156	232	277	312
20	–	172	255	301	337
22	–	208	308	370	412
–	7/8	212	314	376	418
24	–	247	367	441	498

DIA (MM)	INCH	MASS	BL 1770	BL 1960	BL 2160
–	1	277	411	491	546
26	–	290	431	517	581
28	–	336	500	599	681
–	1-1/8	350	521	621	704
30	–	433	644	679	775
32	1-1/4	439	652	769	869
35	1-3/8	523	776	945	1044
36	–	556	826	983	1085
38	1-1/2	623	925	1078	1205
40	–	686	1020	1130	1335

Figures for steel-core ropes. Apart from 1770/1960/2160 N/mm², IPS / EIPS / EEIPS grades are available. For fiber-core breaking force, ask our engineering team. BL in kN; Mass in kg/100m.

ANTI-SPIN FOR TALL LIFTS

The rotation-resistant lay keeps the hook from spinning on a long single fall — essential on tall tower and crawler cranes. Fix both ends against rotation and avoid introducing twist when installing.

SPECIFY WITH

- STEEL CORE (FC ON REQUEST)
- IPS / EIPS / EEIPS
- LANG LAY
- PRE-LUBRICATED
- CUT TO LENGTH

01 — WIRE ROPE SLING

COMPACT WIRE ROPE SLING 18 / 18P

Powerform 18/18P is a high-strength rotation-resistant hoist rope (18×K7, 18×K19S, 18×K26WS, 19×K7). The compaction process gives high fatigue life, increased crushing resistance and abrasion resistance for multi-layer spooling.

KEY FEATURES

- ◆ High-strength rotation-resistant hoist rope.
- ◆ Single- & multi-part hoist reeving systems.
- ◆ High fatigue life + crushing resistance from compaction.
- ◆ Increased abrasion resistance.
- ◆ Fully lubricated in manufacturing.

TYPICAL APPLICATIONS

MOBILE MAIN HOIST

OFFSHORE PEDESTAL

WHIP HOIST

MULTI-LAYER DRUM

DIA (MM)	INCH	MASS	BL 1770	BL 1960	BL 2160
10	–	46	72.6	80.8	88.9
11	7/16	55.7	87.8	101	111
12	–	66.2	104	116	127
–	1/2	74.2	117	135	148
13	–	77.7	123	141	155
14	–	90.2	142	160	177
16	5/8	118	186	209	232
18	–	149	235	266	295
19	3/4	166	262	292	322
20	–	184	290	320	359
22	–	223	351	379	424

DIA (MM)	INCH	MASS	BL 1770	BL 1960	BL 2160
–	7/8	227	358	387	433
24	–	265	418	462	523
–	1	297	468	517	585
26	–	277	490	542	613
28	–	361	569	644	707
–	1-1/8	376	593	672	710
32	1-1/4	471	743	820	920
35	1-3/8	560	884	1000	1052
36	–	596	940	1064	1120
38	1-1/2	664	1048	1186	1248
40	–	736	1161	1314	1382

Steel-core figures. For higher lifting heights, consider a Powerform 18 construction with improved rotational characteristics. IPS / EIPS / EEIPS also available. BL in kN; Mass in kg/100m.

01 — WIRE ROPE SLING

STANDARD WIRE ROPE SLING 18 / 18P

Hyflex 18/18P is a high-strength flexible hoist rope with anti-spin properties — also known as non-rotating rope. Good resistance to rotation, used extensively for tall and tower cranes. Available in fiber-core and wire-strand-core (18×7, 18×19S, 18×26WS, 19×7).

KEY FEATURES

- ◆ Flexible high-strength hoist rope, anti-spin.
- ◆ Good rotation resistance — tall & tower cranes.
- ◆ Consistent performance, fully lubricated.
- ◆ Fiber-core construction also available.
- ◆ Batch-tested for breaking-force compliance.

TYPICAL APPLICATIONS

MOBILE MAIN HOIST

TOWER CRANE MAIN HOIST

TALL SINGLE-FALL

STANDARD WIRE ROPE SLING 18 / 18P — MASS KG/100M · BL KN

DIA (MM)	INCH	MASS FC	MASS WSC	BL 1770	BL 1960	BL 2160
5	—	9.6	10.2	14.5	16.1	17.7
6	—	13.8	14.6	20.9	25	27
7	—	18.8	19.9	28.4	34	36.7
8	—	24.5	26.0	37.2	45	48.6
9	—	31.0	33.0	47	56.5	61
—	3/8	34.6	36.7	52.4	58	63.9
10	—	38.3	40.7	58.1	70	75.6
11	—	46.3	49.2	70.2	84	90.7
12	—	55.1	58.6	83.6	101	109
—	1/2	61.8	65.6	93.6	113	121
13	—	64.7	68.8	98.1	118	127
14	—	75.1	79.8	114	137	148
16	5/8	98.0	104.2	149	180	194
18	—	124	131.9	188	226	244
—	3/4	140	148.5	212	253	273
20	—	153	162.8	232	279	301
22	—	185	197.0	282	339	366
24	—	221	234.4	334	370	408
26	—	259	275.1	392	435	479
28	—	300	319.1	455	504	555
32	—	392	416.8	594	658	725
36	—	496	527.5	752	833	918
40	—	613	651.2	929	1030	1130

Mass given for both Fiber Core (FC) and Wire Strand Core (WSC); breaking force shown for steel-core ropes. FC breaking force on request. IPS / EIPS / EEIPS grades also available.

01 — WIRE ROPE SLING

COMPACT WIRE ROPE SLING 8 / 8P

Powerform 8/8P is a flexible high-strength eight-strand rope with steel core (8×K36WS, 8×K31WS, 8×K26WS, 8×K25F, 8×K19S). The greater surface-contact area from the eight-strand construction delivers exceptional bending-fatigue life — ideal where rope cycles are high.

KEY FEATURES

- ◆ Flexible high-strength eight-strand rope, steel core.
- ◆ Greater surface-contact area → exceptional fatigue life.
- ◆ Good bending-fatigue performance under high cycles.
- ◆ Fully lubricated in manufacturing.
- ◆ FC and plasticated steel core available.

TYPICAL APPLICATIONS

- CONTAINER MAIN HOIST
- BOOM HOIST
- TROLLEY DUTY
- SWIMGRAB

DIA (MM)	MASS	BL 1770	BL 1960	BL 2160
10	44.2	77.0	87.8	94
11	53.5	93.2	103	107
12	63.6	111	126	135
13	74.7	130	144	150
14	86.6	151	172	184
16	113	197	225	241
18	143	249	276	287

DIA (MM)	MASS	BL 1770	BL 1960	BL 2160
19	160	278	317	339
20	177	308	351	376
22	214	373	425	455
24	254	443	506	541
26	299	520	594	635
28	347	604	688	737
32	453	788	899	960

FC is available in all grades above; plasticated steel core also available. Figures for guidance only. BL in kN; Mass in kg/100m.

EIGHT STRANDS, SMOOTHER BENDS

The extra strands spread the rope’s contact across the sheave, lowering the bending stress in each wire — which is why an eight-strand rope outlasts a six-strand of the same diameter on high-cycle container and trolley duty.

SPECIFY WITH

- STEEL / FC / PLASTICATED CORE
- IPS / EIPS / EEIPS
- REGULAR OR LANG LAY
- PRE-LUBRICATED
- CUT TO LENGTH

02 — WIRE ROPE SLING

STANDARD WIRE ROPE SLING 8 & 8×19

Two flexible eight-strand options. Hyflex 8/8P (8×36WS, 8×31WS) is the high-strength choice for container crane main hoist, boom hoist and trolley duty; Hyflex 8×19 (8×26WS, 8×25F, 8×19S) is the economical eight-strand alternative where the compacted Powerform wire is not required.

HYFLEX 8 / 8P · 8×36WS / 8×31WS

DIA (MM)	INCH	MASS	BL 1770	BL 1960	BL 2160
12	–	61.3	90.7	105	117
–	1/2	68.7	102	123	131
13	–	72	106	118	130
14	–	83.5	124	143	160
16	5/8	109	161	187	208
18	–	138	204	239	267
19	3/4	154	227	269	300
20	–	170	252	279	308
22	–	206	305	356	400
24	–	245	363	423	475
26	–	288	426	500	562
28	–	334	494	572	642
32	1-1/4	436	645	747	836
35	–	522	772	855	942
36	–	552	817	935	1053

HYFLEX 8×19 / 8×19P · 8×26WS / 8×25F / 8×19S

DIA (MM)	MASS	BL 1570	BL 1770	BL 1960	BL 2160
13	71.6	94.4	106	118	130
14	83.1	110	124	143	160
16	109	143	161	187	208
18	137	181	204	239	267
20	170	224	252	279	308
22	205	271	305	356	400
24	244	322	363	423	475
26	287	378	426	500	562
28	332	438	494	572	642
32	428	565	637	747	836

Steel-core figures; FC and plasticated steel core available in all grades. Also available as Hyflex 8×29F. IPS / EIPS / EEIPS grades on request. BL in kN; Mass in kg/100m.

WHICH EIGHT-STRAND?

Choose Hyflex 8 / 8P (6×36-pattern strands) where breaking force and fatigue life are critical on container and boom hoists; choose Hyflex 8×19 where the duty is lighter and the compacted Powerform wire is not required.

EIGHT-STRAND STRENGTHS

- ◆ Large surface contact — long bending-fatigue life.
- ◆ Flexible and easy to spool.
- ◆ FC and plasticated steel core available.
- ◆ IPS / EIPS / EEIPS grades on request.

01 — WIRE ROPE SLING

COMPACT WIRE ROPE SLING 6 / 6P

Powerform 6/6P is a compacted six-strand rope with independent wire rope core (6×K36WS, 6×K31WS, 6×K26WS, 6×K25F, 6×K19S). Consistent performance, batch-tested, and fully lubricated in manufacturing.

KEY FEATURES

- ◆ Compacted six-strand rope, IWRC.
- ◆ Higher breaking load vs. equivalent round-strand.
- ◆ Consistent performance, batch-tested.
- ◆ Fully lubricated in manufacturing.
- ◆ FC & plasticated steel core available.

TYPICAL APPLICATIONS

- CRANE MAIN HOIST
- GENERAL LIFTING
- HEAVY SLING
- MULTI-LAYER DRUM

DIA (MM)	MASS	BL 1770	BL 1960
8	29.1	46.4	51.4
10	45.4	69.5	85.7
11	54.9	83.8	98.6
12	65.4	104	116
13	76.7	118	147
14	89	137	170
16	116	178	218
18	147	225	276
19	164	251	304
20	182	278	335

DIA (MM)	MASS	BL 1770	BL 1960
22	220	336	400
24	262	400	489
26	307	491	543
28	356	545	657
32	465	712	846
35	556	889	984
36	588	901	1065
38	656	1004	1165
40	726	1112	1295
44	879	1405	1556

Steel-core figures. Apart from 1770/1910 N/mm², IPS / EIPS / EEIPS and 2070 N/mm² grades available. FC also available in all grades. BL in kN; Mass in kg/100m.

MORE STEEL, MORE CAPACITY

Compaction packs more metallic area into the same diameter, so a Powerform 6 carries a higher breaking load than round-strand 6×36 of the same size — with better crush and wear resistance for multi-layer drums.

SPECIFY WITH

- IWRC (FC AVAILABLE)
- IPS / EIPS / EEIPS
- REGULAR OR LANG LAY
- PRE-LUBRICATED
- CUT TO LENGTH

01 — WIRE ROPE SLING

STANDARD WIRE ROPE SLING 6 - 6×36WS / 6×31WS

High-quality flexible 6×36-class crane rope. The 6×36WS Warrington-Seale construction combines superior bending-fatigue life with excellent abrasion resistance — the first choice for demanding multi-layer drum spooling. Steel core, fully lubricated. Available in 1770, 1960 and 2160 N/mm² with IWRC or WSC.

KEY FEATURES

- ◆ 6×36WS Warrington-Seale — superior fatigue life.
- ◆ Excellent abrasion resistance.
- ◆ First choice for multi-layer drum spooling.
- ◆ Steel core, fully lubricated.
- ◆ Batch-tested for breaking-force compliance.

TYPICAL APPLICATIONS

CONTAINER CRANE

DOCKSIDE UNLOADER

LATTICE BOOM

STEELWORK LADLE

FLOATING CRANE

DIA (MM)	MASS	BL 1770	BL 1960	BL 2160
10	41.9	63.0	69.8	76.9
12	60.3	90.7	100	111
14	82.1	124	137	151
16	107	161	179	197
18	136	204	226	249
20	168	252	279	308
22	203	305	338	372
24	241	363	402	443

DIA (MM)	MASS	BL 1770	BL 1960	BL 2160
26	283	426	472	520
28	329	494	547	603
32	429	645	715	787
36	543	817	904	997
40	670	1010	1120	1230
44	811	1220	1350	1490
48	965	1450	1610	1770
52	1133	1700	1890	2080

6×36WS / 6×31WS / 6×29F, IWRC. IPS / EIPS / EEIPS and custom grades available. Imperial sizes 3/8"–2" also produced. BL in kN; Mass in kg/100m.

THE MULTI-LAYER DRUM SPECIALIST

The 6×36WS Warrington-Seale strand combines a fatigue-resistant inner with abrasion-resistant outer wires — the balance that lets it survive repeated spooling on dockside and container-crane drums.

TYPICAL DUTY

CONTAINER CRANE

DOCKSIDE UNLOADER

LATTICE BOOM

STEELWORK LADLE

FLOATING CRANE

01 — WIRE ROPE SLING

STANDARD WIRE ROPE SLING 6×19

High-quality flexible 6×19-class rope with independent wire rope core. Good abrasion resistance combined with bending-fatigue life makes this the workhorse of general crane and lattice-boom hoist service (6×26WS, 6×19W, 6×25F, 6×21F, 6×19S).

KEY FEATURES

- ◆ 6×19 class, IWRC — the general-service workhorse.
- ◆ Good abrasion resistance + fatigue life.
- ◆ Consistent performance, batch-tested.
- ◆ Fully lubricated in manufacturing.
- ◆ Grades 1770 / 1960 / 2160 N/mm².

TYPICAL APPLICATIONS

INDUSTRIAL CRANE

LATTICE BOOM

MINE HOIST

MARINE WINCH

DREDGER

STEEL MILL

DIA (MM)	MASS	BL 1770	BL 1960	BL 2160
6	14.3	22.7	25.1	27.7
8	25.5	40.3	44.7	49.2
10	39.8	63	69.8	76.9
12	57.3	90.7	101	111
14	78	124	137	151
16	102	161	179	197
18	129	204	226	249
20	159	252	279	308
22	193	305	338	372

DIA (MM)	MASS	BL 1770	BL 1960	BL 2160
24	229	363	402	443
26	269	426	472	520
28	312	494	547	603
32	408	645	715	787
36	516	817	904	997
40	637	1010	1120	1230
44	771	1220	1350	1490
48	917	1450	1610	1770

For other 6×19-class constructions and fiber-core ropes, breaking-force details on request. IPS / EIPS / EEIPS and 2070 N/mm² grades available. BL in kN; Mass in kg/100m.

THE GENERAL-SERVICE WORKHORSE

The 6×19 class trades a little fatigue life for more abrasion resistance — the right balance for industrial cranes, lattice booms and mill duty where the rope drags, rubs and works hard every shift.

TYPICAL DUTY

INDUSTRIAL CRANE

LATTICE BOOM

MINE HOIST

MARINE WINCH

DREDGER

STEEL MILL

02 — WIRE ROPE SLING

STANDARD WIRE ROPE SLING 6×29F & 4

Two specialist constructions. Hyflex 6×29F is a high-quality flexible crane rope (Grade B / Grade T per JIS G 3525) for container main hoist, boom hoist and trolley. Hyflex 4 is a four-strand specialist rope (4×39) for demanding fatigue duty.

HYFLEX 6×29F · IWRC

DIA (MM)	MASS	BL 1770	BL 1910
10	42.9	67.7	71.1
12.5	67.0	106	111
14	84.1	133	139
16	109.8	173	182
18	139.0	219	230
20	171.6	271	284
22.4	215.2	340	357
25	268.1	423	444
28	336.3	531	558
31.5	425.7	672	706
35.5	540.6	853	896
40	686.4	1080	1140
45	868.3	1370	1440
50	1072.5	1690	1780

HYFLEX 4 · 4×39 (15-15/9-FC)

DIA (MM)	MASS	BL 1770	BL 1960
22	209	310	336
24	248	369	400
26	291	433	469
28	338	502	544
30	388	576	624
32	441	656	689
34	498	740	802
36	559	830	898
38	622	924	1002
40	690	1002	1082
42.5	779	1131	1221

MARBLE CUTTING ROPE

6×7+WSC galvanized and Powerform 6×K7+WSC ropes (4.80–4.85 mm) for stone & marble cutting — pre-formed, dry, with plasticated core option.

Hyflex 6×29F: steel-core figures; FC on request. Apart from 1770/1910 N/mm², IPS / EIPS / EEIPS and 2070 N/mm² grades available. Hyflex 4 breaking force at 1770 / 1960 N/mm². BL in kN; Mass in kg/100m.

TWO SPECIALISTS, ONE PAGE

Hyflex 6×29F is the flexible, fatigue-tough choice for container and boom hoists; Hyflex 4 (four-strand) is built for the most demanding fatigue duty. Confirm core and grade with our engineering team for critical reeving.

02 — WIRE ROPE SLING

ELEVATOR ROPES

Elevator hoist, compensating and governor ropes to JIS G 3525, in 6×19 and 8×19 classes with fiber or steel core. Pre-stretched ropes available. Minimum design safety factor for elevator service is 10:1.

HOIST & COMPENSATING · 8×19S / 8×19W / 8×25F · BRIGHT

DIA (MM)	MASS	GRADE E 1320	GRADE A 1620	GRADE B 1770
8	22	26	30.8	32.8
10	34.3	40.6	48.1	51.3
11.2	43	51	60.3	64.3
12	49.4	58.5	69.2	73.8
14	67.2	79.6	94.3	100
16	87.8	104	123	131
18	111	132	156	166
20	137	162	192	205
22.4	172	204	241	257
25	214	254	301	320

GOVERNOR ROPE · 6×19 · FIBER CORE (BL KN)

DIA (MM)	MASS	1180/1770	1370/1770	1770 N/MM ²
8	23.0	28.9	31.7	37.4
10	35.9	45.2	49.5	58.4
12	51.7	65.1	71.3	84.1

ELEVATOR SERVICE

Hoist, compensating and governor ropes share the 6×19 / 8×19 classifications with fibre main core (CFN). Pre-stretched (low-elongation) ropes are available to control rope drift in traction-drive systems.

Hoist & compensating breaking loads (kN) by JIS grade; governor rope breaking loads (kN). Mass in kg/100m. Minimum design safety factor for elevator service is 10:1.

WHY 10:1 FOR ELEVATORS

Passenger safety sets the highest design factor in this book — 10:1. Elevator ropes also run continuously over traction sheaves, so pre-stretched, low-elongation constructions are used to control drift and share load evenly across the rope set.

ELEVATOR ROPE DUTIES

- ◆ Hoist (suspension) ropes — carry the car.
- ◆ Compensating ropes — balance hoist-rope weight.
- ◆ Governor ropes — trigger the safety gear.
- ◆ Pre-stretched grades control traction drift.

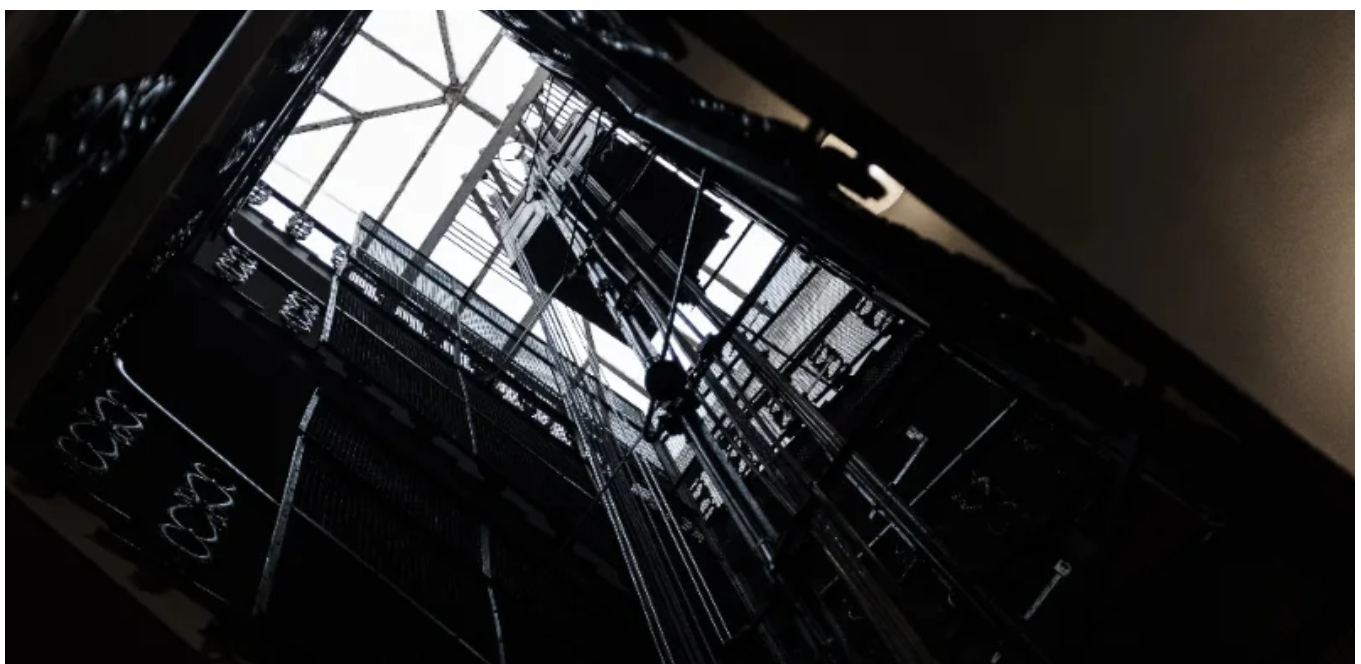

02 — WIRE ROPE SLING

OIL & GAS — DRILL / SAND LINE

Oil-field ropes to API 9A and ASTM A1023. Drill lines (6×26WS / 6×19S) carry the load of the travelling block and string; sand lines (6×7) provide kink resistance and easy splicing for swabbing and sand-coring. Large outer wires give exceptional spooling and wear resistance.

DRILL LINE · 6×26WS / 6×19S · IWRC (BL KN)

INCH	MM	MASS	EIPS	EEIPS
3/4	19	155	262	288
7/8	22	211	354	389
1	26	275	460	506
1-1/8	29	348	568	636
1-1/4	32	430	711	782
1-3/8	35	521	854	943
1-1/2	38	619	1010	1112
1-5/8	42	726	1170	1300
1-3/4	45	844	1360	1500
1-7/8	48	967	1550	1710
2	52	1100	1760	1930

SAND LINE · 6×7 GALVANIZED (BL KN)

INCH	MASS	IPS	EIPS
3/8	31.2	52.1	—
7/16	43	70.5	77.6
1/2	57	91.6	101
9/16	71	116	127
5/8	88	141	155

DETERIORATING FORCES

Abrasion · drum & sheave fatigue · crushing from multi-layer winding · shock load. The rope must combine flexibility, abrasion resistance and a stable construction that absorbs crushing forces.

Reference standards: API 9A, ASTM A1023 (drawn-galvanized / ungalvanized). Figures for guidance only. BL in kN; Mass in kg/100m.

CUT-AND-SLIP KEEPS IT ALIVE

Drilling lines wear hardest at the fixed working points. Planned cut-and-slip moves fresh rope into those zones and retires the worn length — managed by ton-mile service records, not by appearance alone.

WHAT THE ROPE FIGHTS

- ◆ Abrasion at the crown wires.
- ◆ Drum & sheave bending fatigue.
- ◆ Crushing from multi-layer spooling.
- ◆ Shock from sudden string loads.



02 — WIRE ROPE SLING

SHIPPING — 6×24 & ANCHOR MOORING

Shipping and mooring ropes. The 6×24-class fibre-core rope is a flexible, abrasion-resistant shipping rope; anchor-mooring ropes use 6×19 / 6×36 steel-core Titan / EEIPS grade for the highest breaking loads.

6×24 SHIPPING ROPE (BL KN)

DIA (MM)	MASS	1570	1770
10	30.2	44.9	50.6
12	43.5	64.7	72.9
14	59.2	88.0	99.2
16	77.3	115	130
18	97.8	145	164
20	121	180	202
22	146	217	245
24	174	259	292
26	204	304	342
28	237	352	397
30	272	404	456
32	309	460	518
34	349	519	585

ANCHOR MOORING · 6×19 / 6×36 (BL KN)

DIA (MM)	MASS	TITAN / EEIPS
38	605	1112
42	740	1300
45	849	1500
48	965	1710
52	1133	1930
54	1222	2170
58	1409	2420
60	1508	2690
64	1716	2940

MARINE FINISH

Ungalvanized or drawn-galvanized, steel core, right-hand ordinary lay (RHOL). Galvanizing protects against seawater corrosion.

Figures for guidance only; refer to the works certificate for the as-built minimum breaking force. BL in kN; Mass in kg/100m.

BUILT FOR SEAWATER

Mooring and shipping ropes live in salt, spray and grit. Galvanized or drawn-galvanized finishes slow corrosion, while the flexible 6×24 fibre-core construction and right-hand ordinary lay handle and coil easily on deck.

MARINE SELECTION NOTES

- ◆ Galvanize for seawater service.
- ◆ 6×24 FC — flexible, abrasion-resistant shipping rope.
- ◆ 6×19 / 6×36 SC — highest breaking loads for anchor lines.
- ◆ Right-hand ordinary lay for easy handling.

02 — WIRE ROPE SLING

FISHING & COMBINATION — C-MERMAID

Powerform fishing ropes (6×K26WS, 6×K19S, 6×K7) deliver high strength and long life for trawler and marine duty. The c-MERMAID combination rope (6×17S + poly yarn, IWRC) covers individual strands with high-grade engineering polymer — no lubrication needed, high corrosion resistance and excellent flexibility.

POWERFORM FISHING · 6×K26WS / 6×K19S (1570) — BL KN

DIA	MASS FC	MASS SC	BL FC	BL SC
12	54.3	61.6	84.3	92.7
14	73.9	83.9	115	126
16	96.5	110	168	187
18	122	139	212	237
20	151	171	262	292
22	182	207	317	353
24	217	247	377	420
26	255	289	443	493
28	296	336	514	572
30	339	385	590	657
32	386	438	671	748

C-MERMAID COMBINATION ROPE (BL KN)

DIA (MM)	MASS	MIN. BREAKING
14	30.0	46.7
16	39.2	65.1
18	49.6	79.4
20	61.2	93.8
22	74.1	126
24	88.1	146
26	103	183
28	120	206
30	138	239
32	157	277

C-MERMAID ADVANTAGES

- ◆ No lubrication needed — lower operating cost.
- ◆ High resistance to corrosion; galvanized core.
- ◆ High flexibility & better grip; colour to order.
- ◆ BS EN 12385-4; test certificate per lot.

LESS MAINTENANCE AT SEA

The polymer-covered c-MERMAID needs no field lubrication and resists corrosion and snagging — cutting deck maintenance on trawler and marine duty while keeping the flexibility crews want when hauling.

02 — WIRE ROPE SLING

6×19M - 6×7 - 7×7

Small-diameter, multi-strand and stable constructions. 6×19M is a fine-wire general-purpose rope from 4–48 mm in four tensile grades. 6×7 and 7×7 are highly stable, kink-resistant constructions for guy, control and light lifting duty.

6×19M · INDEPENDENT WIRE ROPE CORE (BL KN)

DIA (MM)	MASS	1570	1770	1960	2160	DIA (MM)	MASS	1570	1770	1960	2160
4	6.3	9.1	10.2	11.4	12.5	24	228	300	338	375	413
6	14.2	20.5	23.1	25.5	28.1	26	268	352	397	440	485
8	25.3	33.4	37.6	41.6	45.9	28	310	409	461	510	562
10	39.6	52.1	58.8	65.1	71.7	30	356	469	529	586	645
12	57.0	75.1	84.6	93.7	103	32	405	534	602	666	734
14	77.6	102	115	128	141	36	513	676	762	843	929
16	101	133	150	167	184	40	634	834	940	1041	1147
18	128	169	190	211	232	44	767	1009	1138	1260	1388
20	158	208	235	260	287	48	912	1201	1354	1499	1652
22	192	252	284	315	347						

6×7 & 7×7 · STEEL CORE (BL KN)

DIA (MM)	MASS SC	1570	1770	1960	DIA (MM)	MASS SC	1570	1770	1960
6	14.6	18.8	21.2	23.4	22	195.5	252	284	315
8	25.9	33.4	37.6	41.7	24	232.7	300	338	375
10	40.4	52.1	58.8	65.1	26	273.1	352	397	440
12	58.2	75.1	84.6	93.7	28	316.7	409	461	510
14	79.2	102	115	128	32	413.7	534	602	666
16	103.4	133	150	167	36	523.6	676	762	843
18	130.9	169	190	211	40	646.4	834	940	1040
20	161.6	208	235	260					

Available in fibre or steel core, galvanized or ungalvanized. Figures for guidance only. BL in kN; Mass in kg/100m.

02 — WIRE ROPE SLING

SMALL-DIAMETER ROPE — WHICH CONSTRUCTION?

Three constructions, three jobs. The 6×19M is the flexible, fatigue-tough choice for small hoists and general lifting. The 6×7 and 7×7 are stiff and kink-resistant — built for guy wires, control cables and standing rigging where the rope must hold its shape.

6×19M — FLEXIBLE MULTI-WIRE ROPE

- ◆ 6 strands, each made of 19 fine wires — maximum flexibility in its class.
- ◆ Higher bending fatigue life than 6×7 — better for sheave and drum work.
- ◆ Wide range 4–48 mm covers light crane to heavy hoist.
- ◆ Available galvanized or bright, IWRC or fibre core.
- ◆ Best when you need flexibility AND strength in small diameter.

6×7 & 7×7 — STIFF, STABLE, KINK-RESISTANT

- ◆ 6 or 7 strands of just 7 thick wires — large wires, stiff body.
- ◆ Highly kink-resistant — stays straight under sustained load.
- ◆ Ideal for guy wires, standing rigging and control lines.
- ◆ Easy to hand-splice in the field.
- ◆ 7×7 adds one extra strand for slightly more flexibility.

APPLICATION GUIDE — 6×19M / 6×7 / 7×7

APPLICATION	BEST CONSTRUCTION	WHY
Guy wire / mast stay rope	6×7 or 7×7 SC	Stiff, kink-resistant, easy to splice
Small crane hoist (4–12 mm)	6×19M IWRC	Flexible, good fatigue life over sheaves
Sash / counterweight line	6×7 FC	Smooth, light and stable in guides
Machine / automotive control	7×7 WSC	Compact, kink-resistant, smooth movement
Light rigging / hand sling	6×19M FC	Flexible, lightweight, easy to handle
Sand / swab line (drilling)	6×7 Galvanized	Kink-resistant, corrosion-protected
Temporary tie-back / lashing	6×7 or 7×7	Holds shape under sustained static load
Aerial tramway haul rope	6×7 FC	Stable, smooth, low rotation tendency

FEWER WIRES = MORE STABLE, LESS FLEXIBLE

A 6×7 rope has only 42 wires total — each wire is thick and strong, resists kinking and holds its shape. A 6×19M has 114 finer wires — more flexible and better for bending over sheaves. Choose by the job, not just the breaking load.

TYPICAL APPLICATIONS

GUY WIRE & MAST STAY

CONTROL CABLE

TIE-BACK & LASHING

SAND / SWAB LINE

LIGHT CRANE HOIST

SASH & GUIDE LINE

ARCHITECTURAL RIGGING

AERIAL TRAMWAY

4–48 mm 6×19M DIAMETER RANGE	1570–2160 N/MM ² GRADES AVAILABLE	6×7 MOST KINK-RESISTANT	42 TOTAL WIRES IN A 6×7 ROPE
--	--	-----------------------------------	--

02 — WIRE ROPE SLING

6×S(19) & 6×W(19) + IWRC

The workhorse hoist and crane rope, dual-certified to Thai TIS 514-2527 and European BS EN 12385-4. Typical uses: hoists, general industry, cranes, mine lifting, high-furnace hoisting, oil drilling, excavators, marine and cable cars. Minimum breaking load shown at four tensile grades with approximate mass.

6×S(19) + IWRC · 6×W(19) + IWRC — MINIMUM BREAKING LOAD (KN) & MASS (KG/100M)

DIA (MM)	TIS 1420	TIS 1570	MASS	EN 1770	EN 1960	MASS
6	—	—	—	22.70	25.10	14.40
7	—	—	—	30.90	34.20	19.60
8	35.90	40.50	26.20	40.30	44.70	25.60
9	45.50	51.20	33.20	51.00	56.50	32.40
10	58.10	63.30	41.00	63.00	69.80	40.00
11	67.90	76.50	49.60	76.20	84.40	48.40
12	80.80	91.10	59.00	90.70	100.00	57.60
13	94.80	107.00	68.30	106.00	118.00	67.60
14	110.00	124.00	80.30	124.00	137.00	78.40
16	144.00	162.00	105.00	161.00	179.00	102.00
18	182.00	206.00	133.00	204.00	226.00	130.00
20	224.00	248.00	164.00	252.00	279.00	160.00
22	272.00	306.00	198.00	305.00	338.00	194.00
24	323.00	364.00	237.00	363.00	402.00	230.00
26	379.00	428.00	277.00	426.00	472.00	270.00
28	440.00	496.00	321.00	494.00	547.00	314.00
32	576.00	646.00	420.00	645.00	715.00	410.00

TIS 514-2527 grades 1420 / 1570 N/mm²; BS EN 12385-4 grades 1770 / 1960 N/mm². Figures for guidance only; refer to the works certificate for the as-built minimum breaking force.

02 — WIRE ROPE SLING

SEALE VS WARRINGTON — WHICH WIRE PATTERN?

Same breaking load, different wear life. A 6×S(19) and a 6×W(19) of the same diameter and grade carry nearly identical breaking loads — the difference is entirely in how each wire pattern handles abrasion, bending cycles and sheave contact.

SEALE (S) VS WARRINGTON (W) — PROPERTIES AT A GLANCE

SEALE (S) — LARGE OUTER WIRES

- ◆ Outer wires are bigger than inner wires — thicker "skin" on the rope.
- ◆ Best abrasion resistance in the 6×19 class — resists scraping and rubbing.
- ◆ Use where the rope drags against guides, hoppers or rough surfaces.
- ◆ First choice in mines, quarries, excavators and grab cranes.
- ◆ Resists flattening under heavy side loads on drum flanges.

WARRINGTON (W) — ALTERNATING WIRE SIZES

- ◆ Alternating large and small outer wires — smoother outer surface.
- ◆ Better bending fatigue life than Seale — survives more bend cycles.
- ◆ Gentler on sheave grooves — less groove wear over time.
- ◆ First choice for construction cranes, hoists and general lifting.
- ◆ The balanced option: durable enough to last, flexible enough to bend.

APPLICATION SELECTION GUIDE — 6×S(19) VS 6×W(19)

APPLICATION	BEST CHOICE	WHY
Mine hoist / skip rope	6×S(19) IWRC	Large outer wires resist abrasion on skip guides
Construction crane hoist	6×W(19) IWRC	Better bending life over crane sheaves
Excavator boom & crowd	6×S(19) IWRC	Abrasive bucket and crowd-chain conditions
High-furnace skip rope	6×S(19) IWRC	Hot, dusty, heavily abrasive environment
Marine winch / windlass	6×W(19) IWRC	Repeated drum cycling + corrosion resistance
Oil-field hoist line	6×S(19) IWRC	Abrasion at rotary table & BOP guide
Overhead travelling crane	6×W(19) IWRC	Smooth, well-maintained sheave system
General workshop hoist	6×W(19) IWRC	Balanced duty — fatigue + mild abrasion

SAME STRENGTH, DIFFERENT WEAR LIFE

Both constructions carry essentially the same breaking load. Choose by duty: heavy abrasion (mining, excavating, dredging) → Seale. Repeated bending over sheaves (cranes, hoists, cable cars) → Warrington.

CERTIFIED TO

TIS 514-2527 (THAILAND)

BS EN 12385-4 (EUROPE)

API 9A (OIL & GAS)

JIS G 3525 (JAPAN)

1420–1960

N/MM² TENSILE GRADES

6–32 mm

DIAMETER RANGE

IWRC

STANDARD CORE FOR CRANE WORK

Dual

THAI + EUROPEAN CERTIFIED

02 — WIRE ROPE SLING

GONDOLA ROPES

High-rise construction, chimneys, towers, bridges and glass-facade maintenance demand mobile, continuous-access platforms — gondolas. Gondola ropes use a special tightly-controlled steel with zinc coating applied before wire drawing, giving improved coating adhesion, closer tolerances, better fatigue properties and consistent quality.

POWERFORM 6 GONDOLA · 6×19S/6×17S · STEEL CORE (BL KN)

DIA (MM)	MASS	1770	1960	2160	2400
8.0	27.4	46.4	51.4	56.7	60.0
9.0	34.7	58.8	65.1	71.7	75.8
9.5	38.6	65.5	72.5	80.0	84.5
10.0	42.8	72.6	80.4	88.6	93.6

CONVENTIONAL 6 GONDOLA · STEEL CORE (BL KN)

DIA (MM)	MASS	1770	1960	2160	2400
8.0	24.7	40.3	44.7	49.2	53.0
9.0	31.3	51.0	56.6	62.3	67.1
9.5	35.0	56.9	63.0	69.4	74.7
10.0	36.8	63.0	69.8	76.9	82.8

LUBRICANT & MAINTENANCE

Gondola ropes are normally supplied dry to avoid dust adhesion and roller slippage in open-air use. Inspect sheaves and grooved rollers periodically for wear that can pinch and abrade the rope; machine or replace grooves that bear the rope’s imprint.

STORAGE

Store in a dry, ventilated place, covered against dust. Avoid contact with acids and alkalis, which corrode the rope at the point of contact. Never overload, never exceed the WLL, and always apply the correct design factor.

Powerform 5 / Conventional 5 (5×26WS, 5×19S) and Powerform 4 / Conventional 4 (4×36WS, 4×26WS, 4×19S) gondola ropes are also produced in the 8–10 mm range. Full data on request.

WHY GONDOLA ROPE IS SPECIAL

- ◆ Zinc coating applied before wire drawing — better adhesion.
- ◆ Closer diameter tolerance for grooved rollers.
- ◆ Improved fatigue life for repeated platform travel.
- ◆ Normally supplied dry to avoid dust pick-up.

TYPICAL DUTY

HIGH-RISE FACADES	CHIMNEYS & TOWERS	BRIDGES
GLASS CLEANING	SUSPENDED PLATFORMS	

02 — WIRE ROPE SLING

GONDOLA ROPES — 4 & 5 STRAND

Small-diameter gondola (suspended access platform) ropes in four- and five-strand constructions for tower, chimney, bridge and glass-facade maintenance. Four tensile grades up to 2400 N/mm² give maximum capacity at minimum diameter where rope weight and sheave size are tightly constrained.

POWERFORM 5 GONDOLA [5×26WS, 5×19S]

DIA (MM)	MASS	1770	1960	2160	2400
8.0	24.6	45.3	50.2	55.3	58.4
8.2	25.8	47.6	52.7	58.1	61.3
8.3	26.4	48.8	54.0	59.5	62.8
9.0	31.1	57.3	63.5	70.0	73.9
9.5	34.6	63.9	70.8	78.0	82.3
10.0	38.4	70.8	78.4	85.4	91.2

CONVENTIONAL 5 GONDOLA [5×26WS, 5×19S]

DIA (MM)	MASS	1770	1960	2160	2400
8.0	22.3	40.8	45.2	49.8	52.5
8.2	23.4	42.8	47.4	52.3	55.2
8.3	24.0	43.9	48.6	53.6	56.5
9.0	28.2	51.6	57.2	63.0	66.5
9.5	33.1	57.8	64.0	70.2	74.1
10.0	36.7	64.1	71.0	77.8	82.1

POWERFORM 4 GONDOLA [4×36WS, 4×26WS, 4×19S]

DIA (MM)	MASS	1770	1960	2160	2400
8.0	26.2	44.2	48.9	53.9	55.4
8.2	27.5	46.4	51.4	56.6	58.2
8.3	28.2	47.6	52.6	58.0	59.7
9.0	33.1	55.9	61.9	68.2	70.2
9.5	36.9	62.3	69.0	76.0	78.2
10.0	40.9	69.0	76.4	84.2	86.6

CONVENTIONAL 4 GONDOLA [4×36WS, 4×26WS, 4×19S]

DIA (MM)	MASS	1770	1960	2160	2400
8.0	22.9	42.0	46.6	51.1	52.5
8.2	24.1	44.1	49.0	53.7	55.2
8.3	24.7	45.2	50.1	55.1	56.5
9.0	29.0	53.2	58.9	64.7	66.5
9.5	32.5	59.2	65.7	72.1	74.1
10.0	36.0	65.5	72.5	80.0	82.1

Minimum Breaking Force in kN at 1770 / 1960 / 2160 / 2400 N/mm². Gondola ropes use zinc-coated wire drawn after galvanizing for improved adhesion, closer tolerance and fatigue life; normally supplied dry. Figures for guidance only.

MAXIMUM CAPACITY, MINIMUM DIAMETER

Four- and five-strand gondola ropes reach up to 2400 N/mm² so a small-diameter rope still carries the platform safely – vital where rope weight and sheave size are tightly limited on suspended access systems. Always pair the rope with the correct grooved rollers.

02 — WIRE ROPE SLING

GAC, CONTROL CABLE & PVC-COATED

Galvanized aircraft cable (GAC), automotive control cables and PVC-coated ropes for control, aircraft, architectural and general-purpose duty — to BS EN 12385-4, JASO F 903, RR-W-410H and AS 3569.

GAC / AUTO CONTROL CABLE - GALVANIZED

SIZE RANGE (MM)	CONSTRUCTION	CORE	GRADE N/MM ²
1.0–4.2	1×7 (6/1)	–	1770 / 1960
1.2–3.5	1×12 (9/3)	–	1770 / 1960
1.2–3.5	1×19 (12/6/1)	–	1770 / 1960
1.5–10.0	7×7 (6/1)	WSC	1570–2160
3.0–12.0	7×19 (12/6/1)	WSC	1570–2160
2.0–7.0	6×7 (6/1)	FMC/WSC	1570–2160
3.0–12.0	6×19 (12/6/1)	FMC/WSC	1570–2160
6.0–10.0	6×19S (9/9/1)	FMC/WSC	1770–2160

PVC-COATED ROPE - PVC / PP / PE, VARIOUS COLOURS

INNER (MM)	OUTER (MM)	CONSTRUCTION	GRADE N/MM ²
2	3, 3.5, 4, 5	6×7 / 7×7	1570–1960
3	4, 5, 6	6×19 / 7×19	1570–1960
4	5, 6, 7	6×19 / 7×19	1570–1960
5	6, 7, 8	6×19 / 7×19	1570–1960
6	7, 8, 9	6×19 / 7×19	1570–1960
8	9, 10, 11	6×19 / 7×19	1570–1960
10	11, 12	6×19 / 7×19	1570–1960

Intermediate sizes available to customer requirement. Outer cover available in a wide range of colours.

SELECTING SMALL-DIAMETER CABLE

GALVANIZED AIRCRAFT CABLE (GAC)

- ◆ Tight-tolerance, high-quality small-diameter cable.
- ◆ 7×7 and 7×19 for flexibility; 1×19 for stiffness.
- ◆ Architectural, control and aircraft duty.
- ◆ To BS EN 12385-4, RR-W-410H, AS 3569.

PVC-COATED ROPE

- ◆ Steel core protected by a coloured polymer jacket.
- ◆ PVC / PP / PE covers in a wide range of colours.
- ◆ Clean, non-marking and corrosion-shielded.
- ◆ Intermediate sizes to customer requirement.

TYPICAL APPLICATIONS

ARCHITECTURAL BALUSTRADE

CONTROL CABLES

AIRCRAFT TIE-DOWN

DISPLAY & SIGNAGE

SAFETY LANYARDS

MARINE LIFELINES

AUTOMOTIVE

02 — WIRE ROPE SLING

STRANDS & SPECIALITY STEEL WIRE

Beyond rope. We supply galvanized and ungalvanized strands (4–22 mm) and a full range of speciality steel wires (0.30–11.20 mm) — the same metallurgical control that makes the rope, applied to strand and wire products for utility, automotive, welding and spring industries.

GALVANIZED / UNGALVANIZED STRANDS

PRODUCT	SIZE & CONSTRUCTION	STANDARD	APPLICATION
Galv. Guy Strand	7/2.10–19/2.80 mm	TIS-404 Gr.I	Earthing & support of electric poles
LT Overhead Ground Wire	1/4", 5/16", 3/8" (7-wire)	ASTM A475	Support telecom / optical-fibre on poles
HT Overhead Ground Wire	5/16", 3/8", 7/16"	ASTM A363 EHS/HS	Earthing in HT power lines
Galvanized Strand	3/16"–1/4" (7-wire)	ASTM A640 / A475	Telephone messenger / aerial cable
Roping Strand	1×7, 1×19M, 1×19, 1×36	1570–2160 N/mm ²	General & elevator rope making

SPECIALITY STEEL WIRES

PRODUCT	SIZE (MM)	STANDARD	APPLICATION
Outer Casing Wire	1.10–3.20	JIS G3521	Automotive control cable
MIG-MAG CO ² Welding Wire	0.80–1.60	AWS A5.18 ER70S-6	Auto, pressure vessel, shipbuilding
Spring Wire	0.30–11.20	JIS G3521 SWA/B/C	Mattress, shock absorber, springs
Piano Wire	0.60–8.00	JIS G3522 SWP-A/B/V	Springs (compression, extension, torsion)
Needle Wire	0.53–1.10	JIS G3521	Pins, safety pins, T-pins
Baling / Unitising Wire	2.18–3.14	Customer spec	Cloth, paper & pulp baling
Paper-Clip Wire	0.90–1.25	Customer spec	Paper clips

THE SAME METALLURGY, BEYOND ROPE

Guy strand, overhead ground wire, welding, spring and piano wire are drawn under the same controlled process that makes our rope — so the consistency you trust in a sling carries through to every strand and wire product.

Sizes and standards listed are indicative of the range produced; intermediate sizes and other national standards are available to customer requirement. Confirm grade and finish on the order.

02 — WIRE ROPE SLING

WIRE ROPE SLING WLL & SLING ANGLE

Working load limit (WLL) for single-part mechanical-splice wire-rope slings, EIPS, IWRC, design factor 5:1, to ASME B30.9 / EN 13414. Choker hitch reduces capacity to 75%; a true vertical basket hitch doubles it. The moment a sling leg leaves the vertical, capacity falls with the cosine of the angle — this is the single most common cause of overload in the field.

SINGLE WIRE-ROPE SLING WLL (TONNES) · EIPS

DIA MM (INCH)	VERTICAL	CHOKER 0.75	BASKET 2.0
6.5 (1/4")	0.65	0.49	1.3
8 (5/16")	0.91	0.68	1.8
10 (3/8")	1.15	0.86	2.3
11 (7/16")	1.72	1.29	3.4
13 (1/2")	2.40	1.80	4.8
14 (9/16")	2.80	2.10	5.6
16 (5/8")	3.66	2.75	7.3
18 (11/16")	4.60	3.45	9.2
19 (3/4")	5.14	3.86	10.3
20 (13/16")	5.68	4.26	11.4
22 (7/8")	6.90	5.18	13.8
24 (15/16")	8.20	6.15	16.4
26 (1")	9.62	7.22	19.2
29 (1-1/8")	11.16	8.37	22.3
32 (1-1/4")	14.58	10.94	29.2
35 (1-3/8")	17.44	13.08	34.9
38 (1-1/2")	20.60	15.45	41.2
41 (1-5/8")	22.80	17.10	45.6
44 (1-3/4")	27.60	20.70	55.2
48 (1-7/8")	32.80	24.60	65.6
50 (2")	38.60	28.95	77.2

SLING ANGLE FACTOR

ANGLE †	1-LEG	2-LEG
0° Vertical	1.00	2.00
30° —	0.87	1.73
45° —	0.71	1.41
60° Widest safe	0.50	1.00

† Angle measured from the vertical. Multiply the single-leg vertical WLL by the factor shown. Below 60° from vertical, capacity halves — never rig wider than 60°.

RULE OF THUMB

At 60° from vertical, each leg of a 2-leg sling carries the same load as a single vertical leg — the second leg buys you nothing but tension. Keep included angles tight.

Values are representative for selection only. Always confirm WLL against the specific sling's certificate and termination type. For hand-spliced, swaged-socket or grommet slings the factor differs.

RIGGING THE ANGLE

- | | |
|---|--|
| <p>DO</p> <ul style="list-style-type: none"> ✓ Measure the leg angle from the vertical and apply the factor. ✓ Keep included angles tight — under 60° from vertical. ✓ Use the choker factor (0.75) whenever the sling chokes the load. ✓ Confirm the WLL against the sling's own certificate. | <p>DON'T</p> <ul style="list-style-type: none"> ✗ Never rig wider than 60° from vertical. ✗ Never assume a second leg halves the load — angle decides. ✗ Never apply basket capacity over a tight, small-radius bend. ✗ Never mix hand-spliced and swaged efficiency factors. |
|---|--|

02 — WIRE ROPE SLING

WIRE ROPE SLING WLL — IPS

Rated working load limits for 6×19 / 6×37 IPS (Improved Plow Steel, 1770 N/mm² / 180 kgf/mm²) mechanical-splice slings with IWRC, by hitch type and sling angle, in metric tonnes.

IPS — Improved Plow Steel (1770 N/mm ²)						6×19 / 6×37 · IWRC · SF 5:1			
SIZE IN · MM	WEIGHT KG/100M	MBL T	SINGLE	CHOKER	BASKET	2-LEG		3 & 4-LEG	
						45-60°	30°	45-60°	30°
1/4" 6.0	24.1	2.80	0.56	0.39	1.12	0.79	0.56	1.19	0.84
5/16" 8.0	26.2	4.11	0.82	0.58	1.64	1.16	0.82	1.74	1.23
3/8" 9.5	33.1	5.20	1.04	0.73	2.08	1.47	1.04	2.21	1.56
13/32" 10.0	40.9	6.42	1.28	0.90	2.57	1.82	1.28	2.72	1.93
7/16" 11.0	49.5	7.77	1.55	1.09	3.11	2.20	1.55	3.30	2.33
15/32" 12.0	58.9	9.20	1.84	1.29	3.68	2.60	1.84	3.90	2.76
1/2" 12.7	69.1	10.90	2.18	1.53	4.36	3.08	2.18	4.62	3.27
9/16" 14.2	80.3	12.60	2.52	1.76	5.04	3.56	2.52	5.34	3.78
5/8" 16.0	105	16.40	3.28	2.30	6.56	4.64	3.28	6.96	4.92
11/16" 18.0	133	20.80	4.16	2.91	8.32	5.88	4.16	8.82	6.24
3/4" 19.0	148	23.10	4.62	3.23	9.24	6.53	4.62	9.80	6.93
13/16" 20.0	164	25.70	5.14	3.60	10.28	7.27	5.14	10.90	7.71
7/8" 22.0	198	31.10	6.22	4.35	12.44	8.80	6.22	13.19	9.33
15/16" 24.0	236	37.00	7.40	5.18	14.80	10.46	7.40	15.70	11.10
1" 25.4	277	43.40	8.68	6.08	17.36	12.27	8.68	18.41	13.02
1-1/8" 28.0	321	50.40	10.08	7.06	20.16	14.25	10.08	21.38	15.12
1-1/4" 32.0	419	65.80	13.16	9.21	26.32	18.61	13.16	27.91	19.74
1-3/8" 35.0	501	78.70	15.74	11.02	31.48	22.26	15.74	33.38	23.61
1-1/2" 38.0	591	92.80	18.56	12.99	37.12	26.24	18.56	39.37	27.84
1-5/8" 41.0	660	103.00	20.60	14.42	41.20	29.13	20.60	43.69	30.90
1-3/4" 44.0	792	124.00	24.80	17.36	49.60	35.07	24.80	52.60	37.20
1-7/8" 48.0	942	148.00	29.60	20.72	59.20	41.85	29.60	62.78	44.40
2" 50.0	1100	173.00	34.60	24.22	69.20	48.92	34.60	73.39	51.90

WORKING LOAD LIMIT · TONNES · MECHANICAL SPLICE

Calculated to ASME B30.9 with a 5:1 design factor. Single leg = MBL ÷ 5. Choker ×0.70 · vertical basket ×2.0 · 2-leg 45-60° ×1.41 · 2-leg 30° ×1.0 · 3 & 4-leg 45-60° ×2.12 · 3 & 4-leg 30° ×1.5. Angles measured from the horizontal; below 30° not permitted. Mass in kg/100m.

02 — WIRE ROPE SLING

WIRE ROPE SLING WLL — EIPS

Rated working load limits for 6×19 / 6×37 EIPS (Extra Improved Plow Steel, 1960 N/mm² / 200 kgf/mm²) mechanical-splice slings with IWRC, by hitch type and sling angle, in metric tonnes.

EIPS — Extra Improved Plow Steel (1960 N/mm ²)						6×19 / 6×37 · IWRC · SF 5:1			
SIZE IN · MM	WEIGHT KG/100M	MBL T	SINGLE	CHOKER	BASKET	2-LEG		3 & 4-LEG	
						45-60°	30°	45-60°	30°
1/4" 6.0	24.1	3.25	0.65	0.45	1.30	0.92	0.65	1.38	0.98
5/16" 8.0	26.2	4.56	0.91	0.64	1.82	1.29	0.91	1.93	1.37
3/8" 9.5	33.1	5.76	1.15	0.81	2.30	1.63	1.15	2.44	1.73
13/32" 10.0	40.9	7.12	1.42	1.00	2.85	2.01	1.42	3.02	2.14
7/16" 11.0	49.5	8.61	1.72	1.21	3.44	2.43	1.72	3.65	2.58
15/32" 12.0	58.9	10.30	2.06	1.44	4.12	2.91	2.06	4.37	3.09
1/2" 12.7	69.1	12.00	2.40	1.68	4.80	3.39	2.40	5.09	3.60
9/16" 14.2	80.3	14.00	2.80	1.96	5.60	3.96	2.80	5.94	4.20
5/8" 16.0	105	18.30	3.66	2.56	7.32	5.18	3.66	7.76	5.49
11/16" 18.0	133	23.00	4.60	3.22	9.20	6.50	4.60	9.76	6.90
3/4" 19.0	148	25.70	5.14	3.60	10.28	7.27	5.14	10.90	7.71
13/16" 20.0	164	28.40	5.68	3.98	11.36	8.03	5.68	12.05	8.52
7/8" 22.0	198	34.50	6.90	4.83	13.80	9.76	6.90	14.63	10.35
15/16" 24.0	236	41.00	8.20	5.74	16.40	11.59	8.20	17.39	12.30
1" 25.4	277	48.10	9.62	6.73	19.24	13.60	9.62	20.40	14.43
1-1/8" 28.0	321	55.80	11.16	7.81	22.32	15.78	11.16	23.67	16.74
1-1/4" 32.0	419	72.90	14.58	10.21	29.16	20.62	14.58	30.92	21.87
1-3/8" 35.0	501	87.20	17.44	12.21	34.88	24.66	17.44	36.99	26.16
1-1/2" 38.0	591	103.00	20.60	14.42	41.20	29.13	20.60	43.69	30.90
1-5/8" 41.0	660	114.00	22.80	15.96	45.60	32.24	22.80	48.36	34.20
1-3/4" 44.0	792	138.00	27.60	19.32	55.20	39.03	27.60	58.54	41.40
1-7/8" 48.0	942	164.00	32.80	22.96	65.60	46.38	32.80	69.57	49.20
2" 50.0	1100	193.00	38.60	27.02	77.20	54.58	38.60	81.87	57.90

WORKING LOAD LIMIT · TONNES · MECHANICAL SPLICE

Calculated to ASME B30.9 with a 5:1 design factor. Single leg = MBL ÷ 5. Choker ×0.70 · vertical basket ×2.0 · 2-leg 45-60° ×1.41 · 2-leg 30° ×1.0 · 3 & 4-leg 45-60° ×2.12 · 3 & 4-leg 30° ×1.5. Angles measured from the horizontal; below 30° not permitted. Mass in kg/100m.

02 — WIRE ROPE SLING

MULTI-PART BRAID SLINGS

A braided sling is built from several parts of wire rope tucked together into one flexible body — delivering far higher capacity than a single rope of the same diameter, while staying soft and easy to handle around the load. KCB braid slings are produced in 3-, 4-, 6- and 8-part constructions with a hand-tucked splice and fiber core — our recommended choice for heavy, repetitive and awkward lifts where a single-part rope would be too stiff.

WHY CHOOSE A BRAID SLING

- ◆ Multiple rope parts share the load — high capacity at a small body diameter.
- ◆ Hand-tucked splice develops the full braided body; no bulky pressed ferrules.
- ◆ Exceptionally flexible — grips and hugs irregular loads far better than single-part rope.
- ◆ Fiber core for maximum flexibility; built in 3, 4, 6 and 8-part.
- ◆ Rated for vertical, choker and vertical-basket hitches in IPS and EIPS grades.

TYPICAL APPLICATIONS

HEAVY PLATE & COIL	FORGING & DIES	FOUNDRY & LADLE
STRUCTURAL STEEL	SHIPYARD & MODULES	
MACHINERY MOVING	BUNDLE CHOKING	
PRESS & MOULD HANDLING		

THREE HITCH CONFIGURATIONS

<p>VERTICAL</p> <p>Sling hangs straight from the pin to the load — the base rated capacity of the braid.</p>	<p>CHOKER</p> <p>Sling passes around the load and back through its own eye — approximately 87% of the vertical rated capacity. Choke angle must be 120° or greater; reduce capacity further if less than 120°.</p>	<p>VERTICAL BASKET</p> <p>Both eyes on the hook, load cradled in the bight — up to twice the vertical capacity. Basket hitch rated at a D/d ratio of at least 25× the component rope diameter at the point of load contact.</p>
---	---	--

HOW TO READ THE CAPACITY TABLES

Rated capacities are given in tons of 2,000 lb for each rope diameter, hitch type and rope grade — IPS (Improved Plow Steel) and EIPS (Extra Improved Plow Steel). The ratings apply only to 6×19 and 6×36 classification wire rope with a hand-tucked splice and fiber core. Nominal Splice Efficiency (NSE) for multi-part braided slings is 0.70. Choker hitch ratings assume choke angle ≥ 120°; basket hitch ratings are based on D/d ≥ 25× component rope diameter. Tables: RC 3-1 (3-part), RC 3-15 (4-part), RC 3-29 (6-part) and RC 3-43 (8-part).

02 — WIRE ROPE SLING

BRAID SLING CAPACITY — 3 & 4-PART

Rated capacity in tons of 2,000 lb for 3-part and 4-part hand-tucked braid slings, by rope diameter, hitch and grade — IPS and EIPS. Vert = vertical (straight pull) · Ch = choker · Bk = vertical basket.

RC 3-1 · 3-PART BRAID

ROPE Ø	VERT IPS	VERT EIPS	CHK IPS	CHK EIPS	BSKT IPS	BSKT EIPS
3/16	0.65	0.72	0.57	0.63	1.3	1.4
1/4	1.2	1.3	1.0	1.1	2.3	2.5
5/16	1.8	2.0	1.6	1.7	3.6	3.9
3/8	2.6	2.8	2.2	2.5	5.1	5.6
7/16	3.5	3.8	3.0	3.3	6.9	7.6
1/2	4.5	4.9	3.9	4.3	9.0	9.9
9/16	5.7	6.2	5.0	5.5	11	12
5/8	7.0	7.7	6.1	6.8	14	15
3/4	10	11	8.7	9.6	20	22
7/8	14	15	12	13	27	30
1	18	19	15	17	35	39
1-1/8	22	24	19	21	44	49
1-1/4	27	30	24	26	54	60
1-3/8	33	36	29	31	65	72
1-1/2	39	43	34	37	77	85
1-5/8	45	49	39	43	90	99
1-3/4	52	57	46	50	104	115
1-7/8	59	65	52	57	118	130
2	67	74	59	65	134	148

RC 3-15 · 4-PART BRAID

ROPE Ø	VERT IPS	VERT EIPS	CHK IPS	CHK EIPS	BSKT IPS	BSKT EIPS
3/16	0.87	0.95	0.76	0.84	1.7	1.9
1/4	1.5	1.7	1.3	1.5	3.1	3.4
5/16	2.4	2.6	2.1	2.3	4.8	5.2
3/8	3.4	3.8	3.0	3.3	6.8	7.5
7/16	4.6	5.1	4.1	4.5	9.3	10
1/2	6.0	6.6	5.2	5.8	12	13
9/16	7.6	8.3	6.6	7.3	15	17
5/8	9.4	10	8.2	9.0	19	21
3/4	13	15	12	13	27	29
7/8	18	20	16	17	36	40
1	23	26	20	23	47	51
1-1/8	29	32	26	28	59	65
1-1/4	36	40	32	35	72	80
1-3/8	44	48	38	42	87	96
1-1/2	52	57	45	50	103	113
1-5/8	60	66	52	58	120	132
1-3/4	69	76	61	67	139	153
1-7/8	79	87	69	76	158	174
2	90	99	78	86	179	197

Hand-tucked splice, fiber core. Applies only to 6×19 and 6×36 wire rope. NSE = 0.70. Vertical = straight pull · Choker ≈ 0.87 × vertical (choke angle ≥ 120°) · Basket up to 2 × vertical at D/d ≥ 25× component rope diameter.

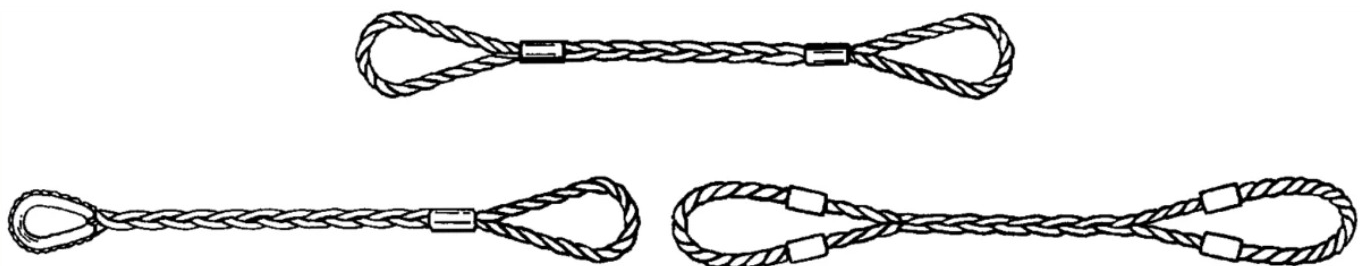

02 — WIRE ROPE SLING

BRAID SLING CAPACITY — 6 & 8-PART

Rated capacity in tons of 2,000 lb for 6-part and 8-part hand-tucked braid slings, by rope diameter, hitch and grade — IPS and EIPS. Vert = vertical (straight pull) · Chk = choker · Bskt = vertical basket.

RC 3-29 · 6-PART BRAID

ROPE Ø	VERT IPS	VERT EIPS	CHK IPS	CHK EIPS	BSKT IPS	BSKT EIPS
3/16	1.3	1.4	1.1	1.3	2.6	2.9
1/4	2.3	2.5	2.0	2.2	4.6	5.1
5/16	3.6	3.9	3.1	3.4	7.2	7.9
3/8	5.1	5.6	4.5	4.9	10	11
7/16	6.9	7.6	6.1	6.7	14	15
1/2	9.0	9.9	7.9	8.7	18	20
9/16	11	12	10	11	23	25
5/8	14	15	12	14	28	31
3/4	20	22	17	19	40	44
7/8	27	30	24	26	54	60
1	35	39	31	34	70	77
1-1/8	44	49	39	43	88	97
1-1/4	54	60	47	52	109	119
1-3/8	65	72	57	63	131	144
1-1/2	77	85	68	74	155	170
1-5/8	90	99	79	87	180	198
1-3/4	104	115	91	100	208	229
1-7/8	118	130	104	114	237	261
2	134	148	118	129	269	296

RC 3-43 · 8-PART BRAID

ROPE Ø	VERT IPS	VERT EIPS	CHK IPS	CHK EIPS	BSKT IPS	BSKT EIPS
3/16	1.7	1.9	1.5	1.7	3.5	3.8
1/4	3.1	3.4	2.7	3.0	6.1	6.8
5/16	4.8	5.2	4.2	4.6	9.5	10
3/8	6.8	7.5	6.0	6.6	14	15
7/16	9.3	10	8.1	8.9	19	20
1/2	12	13	10	12	24	26
9/16	15	17	13	15	30	33
5/8	19	21	16	18	37	41
3/4	27	29	23	26	53	59
7/8	36	40	32	35	72	79
1	47	51	41	45	94	103
1-1/8	59	65	52	57	118	130
1-1/4	72	80	63	70	145	159
1-3/8	87	96	76	84	174	191
1-1/2	103	113	90	99	206	227
1-5/8	120	132	105	115	240	264
1-3/4	139	153	122	134	278	306
1-7/8	158	174	138	152	316	347
2	179	197	157	172	358	394

Hand-tucked splice, fiber core. Applies only to 6×19 and 6×36 wire rope. NSE = 0.70. Vertical = straight pull · Choker ≈ 0.87 × vertical (choke angle ≥ 120°) · Basket up to 2 × vertical at D/d ≥ 25× component rope diameter.

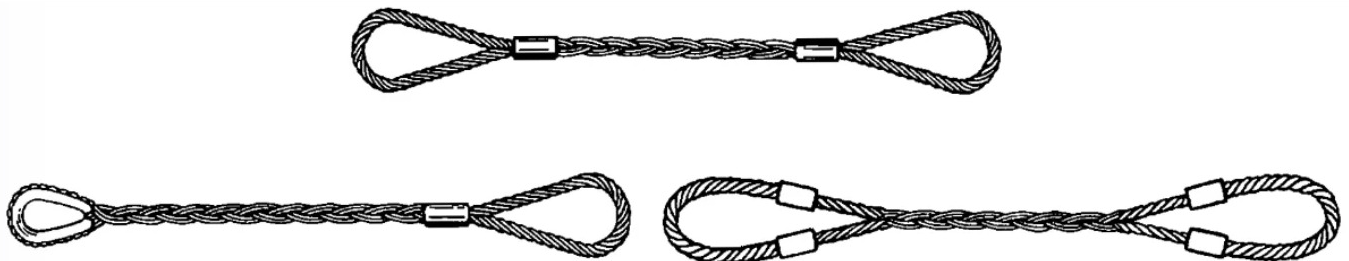

02 — WIRE ROPE SLING

TERMINATIONS, DAMAGE & INSPECTION

A sling is only as strong as its weakest end. End-termination type sets the efficiency of the whole assembly; daily pre-use inspection catches the damage modes that cause failure. When in doubt — take it out of service.

END-TERMINATION EFFICIENCY

TERMINATION	EFFICIENCY	NOTES
Spelter / Resin Socket	100%	Permanent end fitting, highest efficiency
Swaged Socket	100%	Pressed steel sleeve, full-strength
Flemish Eye + Mechanical Sleeve	90–95%	Standard factory sling eye
Hand-Spliced Eye	80–90%	Varies with diameter & tucks
Wedge Socket	70–80%	Field-adjustable, re-usable
U-Bolt Wire Clips	80%	Field termination, torque-critical

SIX DAMAGE MODES — RETIRE IMMEDIATELY IF SEEN

BIRD-CAGING

Strands unlay into a basket shape after shock load or sudden release of tension.

KINKING

A permanent loop pulled tight; the rope is irreversibly damaged and must be retired.

CRUSHING

Flattened rope from multi-layer drum cross-winding or sheave pinch.

BROKEN WIRES

Random or valley breaks; retire per the broken-wire-per-lay criterion.

CORROSION

Pitting and rust reduce metallic area and mask internal damage.

REVERSE BENDING

S-shaped reverse bends drastically cut fatigue life.

RETIREMENT CRITERIA (EN 13414 / ASME B30.9)

Retire a wire-rope sling on any of: broken wires (e.g. ≥ 10 randomly distributed in one rope lay, or ≥ 5 in one strand in one lay); diameter reduction $> 7\text{--}10\%$; severe corrosion or pitting; kinking, crushing or bird-caging; heat damage or arc strike; a deformed, cracked or worn end fitting.

02 — WIRE ROPE SLING

MECHANICAL DAMAGE & TERMINATION EFFICIENCY

None of these damages are repairable. Inspect before every use; when in doubt, take the rope out of service. End terminations also set the strength of the whole assembly: the efficiency rating is the share of the rope’s breaking force the fitting will develop when correctly attached.

SIX MECHANICAL DAMAGE MODES — RETIRE IF SEEN

<p>BIRD-CAGING</p> <p>Strands forced open into a basket by shock load, torque build-up, or a tight sheave.</p>	<p>KINKING</p> <p>A loop pulled tight into a permanent kink — irreversible; retire the rope.</p>	<p>LAYER CRUSHING</p> <p>Flattening from multi-layer cross-winding or scrubbing between drum wraps.</p>
<p>PROTRUDING CORE</p> <p>Core pushed out by shock loading, torque, or incorrect rope design.</p>	<p>BROKEN WIRES</p> <p>Random or valley breaks at the crown or between strands; count per lay length.</p>	<p>CORROSION</p> <p>Pitting and rust cut the metallic area and hide internal deterioration.</p>

END-TERMINATION EFFICIENCY

TERMINATION	EFFICIENCY
Spelter / resin socket	100%
Open / closed swaged socket	90%
Aluminium splice + HD thimble	90%
Flemish eye + steel sleeve	90%
Threaded stud / button	90%
Forged wire-rope clips	80%
Wedge socket	75–80%

RETIREMENT CRITERIA

Retire on ≥ 10 random broken wires in one lay length (or ≥ 5 in one strand), diameter loss $> 7-10\%$, severe corrosion, kinking, crushing, bird-caging, heat or arc damage, or any cracked/worn end fitting. Per ISO 4309, EN 13414 and ASME B30.9.

Hand-spliced terminations are not recommended for crane rope. Do not repair any fitting — replace it.

02 — WIRE ROPE SLING

APPLICATION GUIDE & DO / DON'T

The right rope for the right job. Construction governs how a rope behaves long before its breaking load matters. This guide maps common duties to the construction we'd specify first — but always confirm with our engineering team for critical lifts.

FIRST-CHOICE CONSTRUCTION BY APPLICATION

APPLICATION	FIRST-CHOICE CONSTRUCTION	WHY
Tower crane main hoist	STANDARD WIRE ROPE SLING 35	Anti-spin, no rotation on single-fall hoists
Mobile crane main hoist	COMPACT WIRE ROPE SLING 35	Compacted strands, multi-layer drum spooling
Container crane hoist	STANDARD WIRE ROPE SLING 8	8-strand — large contact area, long fatigue life
General workshop crane	STANDARD WIRE ROPE SLING 6×19	Balanced abrasion & bending fatigue
Offshore / marine winch	COMPACT WIRE ROPE SLING 6 (galv.)	Corrosion + crush resistance
Lifting sling (rigging)	6×36 IWRC mechanical splice	Flexible body, high-efficiency eye
Elevator	8×19 / 6×19 fibre core	Traction grade, 10:1 factor, pre-stretched
Architectural / control	7×7 / 7×19 GAC or PVC-coated	Stable, kink-resistant, clean finish

DO

- ✓ Match construction, grade and core to the actual duty cycle.
- ✓ Respect the sling-angle factor — keep included angles tight.
- ✓ Protect rope from sharp edges with sleeves or packing.
- ✓ Inspect before every use; log periodic inspections.
- ✓ Store dry, off the ground, away from acids & heat.
- ✓ Use the certificate & serial number for traceability.

DON'T

- ✗ Never exceed the WLL or consume the safety factor.
- ✗ Never shock-load — it can bird-cage the rope.
- ✗ Never drag rope or pull it over sharp unprotected edges.
- ✗ Never use kinked, crushed or corroded rope.
- ✗ Never run rope over worn or grooved sheaves.
- ✗ Never mix unmatched components in one assembly.

CONSTRUCTION FIRST, CAPACITY SECOND

A rope that breaks the chart on paper still fails early if its construction is wrong for the duty. Pick the construction for how the rope will bend, drag and cycle — then confirm the breaking load.

WHEN IN DOUBT, ASK ABOUT

- DUTY CYCLE & LINE SPEED
- SHEAVE & DRUM SIZES
- ENVIRONMENT & CORROSION
- REQUIRED CERTIFICATION
- END TERMINATIONS

REFERENCE

CONVERSION TABLES

Quick reference. Diameter, force, tensile-strength and weight conversions for moving between metric and imperial rope data — and the one equation that underpins every working load limit in this book.

DIAMETER — INCH ↔ MM

INCH	MM	INCH	MM
5/32	3.97	1-1/8	28.6
3/16	4.76	1-1/4	31.8
1/4	6.35	1-3/8	34.9
5/16	7.94	1-1/2	38.1
3/8	9.53	1-3/4	44.5
7/16	11.1	2	50.8
1/2	12.7	2-1/4	57.2
9/16	14.3	2-1/2	63.5
5/8	15.9	3	76.2
3/4	19.0	3-1/2	88.9
7/8	22.2	4	101.6
1	25.4		

UNITS & FORMULAE

QUANTITY	CONVERSION
Length	1 m = 1000 mm = 3.281 ft = 39.37 in
Force	1 kN = 101.97 kp = 0.10197 t-f = 224 lbf
Tensile strength	1 N/mm ² = 0.10197 kp/mm ² = 145.04 psi = 10 bar
Cross-section	1 mm ² = 0.00155 in ²
Weight	1 metric t = 1000 kg = 1.102 short t = 0.9842 long t = 2204.6 lb
Weight / length	1 kg/m = 0.672 lb/ft
WLL ↔ BL	WLL = Minimum Breaking Load ÷ Design Factor

THE MASTER EQUATION · WLL = MBL ÷ DESIGN FACTOR

Every value in this catalogue flows from this relationship. A 5:1 factor means the rope will not break until five times its rated working load — that margin is for shock and emergency, never for everyday lifting.

NUMBERS WORTH MEMORISING

8.896 TONS × THIS = KN	25.4 INCH → MM	0.672 KG/M → LB/FT	5:1 WR SLING DESIGN FACTOR
----------------------------------	--------------------------	------------------------------	--------------------------------------



03

POLYESTER SLING

TRACK by KCB — colour-coded polyester webbing slings, round slings and ratchet straps, woven and certified at our own facility in Pathum Thani.

WEBBING SLING 1-24 T

ROUND SLING 1-50 T

RATCHET STRAP 1-12 T

EN 1492-1 / 1492-2 / 12195-2

SAFETY FACTOR 7:1

03 — POLYESTER SLING

THE TRACK POLYESTER RANGE

TRACK is KCB Sling’s own polyester brand — three product families, all woven from 100% polyester yarn, colour-coded by capacity and certified to the European standards. Polyester is light, will not mar a finished surface, has a gentle 3–5% elongation that cushions the load, and loses no strength in water.

<p>A</p> <p>POLYESTER WEBBING SLING</p> <p>2 / 3 / 4-ply flat webbing with reinforced lifting eyes. WLL 1–24 t. 100% polyester to EN 1492-1, safety factor 7:1. Each capacity has its own colour code.</p>	<p>B</p> <p>POLYESTER ROUND SLING</p> <p>Endless polyester core inside a two-ply woven heavy-duty sleeve. WLL 1–50 t. 100% polyester to EN 1492-2, safety factor 7:1. Double-layer seamless cover protects the load-bearing yarns.</p>	<p>C</p> <p>RATCHET STRAP WITH HOOK</p> <p>“TRACK” ratchet strap with custom hook. WLL 1–12 t to EN 12195-2. Light and handy, low-strain, wear-resistant. Buckle 100% aluminium, strap 100% polyester.</p>
--	--	--



WEBBING SLING — REINFORCED EYES, COLOUR = CAPACITY



ROUND SLING — DOUBLE-WALL WOVEN SLEEVE

THE COLOUR CODE (EN 1492)

1 T VIOLET	2 T GREEN	3 T YELLOW	4 T GREY	5 T RED	6 T BROWN	8 T BLUE
10 T ORANGE						

The same colour always means the same rated capacity — on every TRACK webbing and round sling. Capacities above 10 t use combinations of width, ply and thick-fabric construction in the same colour family.

LASHING IS NOT LIFTING

A ratchet strap is certified for cargo restraint (EN 12195-2) — not lifting. A webbing or round sling is certified for lifting (EN 1492). Never swap them — the standards, safety factors and failure modes are completely different.

03 — POLYESTER SLING · TYPE A

POLYESTER WEBBING SLING

2 / 3 / 4-ply flat polyester webbing sling with reinforced lifting eyes, working load limit 1–24 tonnes. The wide bearing face spreads the load and protects delicate, machined or painted surfaces.

TECHNICAL SPECIFICATIONS

- ◆ Constructed of 100% polyester.
- ◆ Certified standard EN 1492-1.
- ◆ Safety factor 7 : 1.
- ◆ Each working load has its own colour code.
- ◆ Working temperature –40 °C to +100 °C.
- ◆ Excellent resistance to acids, oils, ultra-violet, rot & mildew.
- ◆ Light & easy to handle, store and clean.
- ◆ No loss of strength in water.
- ◆ Elongation 3–5%.



SEWN & BAR-TACKED IN-HOUSE



2 / 3 / 4-PLY, REINFORCED EYES

CHEMICAL RESISTANCE — POLYESTER (PES)

CHEMICAL RESISTANT INFORMATION CHART

ACIDS	ALKALIS	ETHERS	ALDEHYDES	ALCOHOLS	OILS	ORGANIC SOLVENTS	WATER & SEAWATER
OK	NO	NO	NO	OK	OK	OK	OK

Guidance only; resistance depends on concentration, temperature and exposure time. Polyester is attacked by alkalis — for alkaline or unknown environments, consult our engineering team.

03 — POLYESTER SLING · TYPE A

WEBBING SLING — WORKING LOAD LIMIT CHART

Working load limits for TRACK polyester webbing slings to EN 1492-1, values in kilograms. Each mode factor (shown in the column head) multiplies the straight-pull WLL — a parallel basket nearly doubles capacity, while choking reduces it to 80%.

POLYESTER WEBBING SLING — WLL (KG) BY HITCH & CONFIGURATION

WIDTH · WLL	STRAIGHT *1.0	CHOKED *0.8	BASKET 0-7° *2.0	BASKET 7-45° *1.4	BASKET 45-60° *1.0	2-SLING ≤45° *1.4	2-SLING CHK ≤45° *1.12	2-SLING 45-60° *1.0	2-SLING CHK 45-60° *0.8
30 mm · 1 t	1000	800	2000	1400	1000	1400	1120	1000	800
60 mm · 2 t	2000	1600	4000	2800	2000	2800	2240	2000	1600
90 mm · 3 t	3000	2400	6000	4200	3000	4200	3360	3000	2400
120 mm · 4 t	4000	3200	8000	5600	4000	5600	4480	4000	3200
150 mm · 5 t	5000	4000	10000	7000	5000	7000	5600	5000	4000
180 mm · 6 t	6000	4800	12000	8400	6000	8400	6720	6000	4800
240 mm · 8 t	8000	6400	16000	11200	8000	11200	8960	8000	6400
300 mm · 10 t	10000	8000	20000	14000	10000	14000	11200	10000	8000
300 mm thick · 12 t	12000	9600	24000	16800	12000	16800	13440	12000	9600
300 mm 3-ply · 15 t	15000	12000	30000	21000	15000	21000	16800	15000	12000
300 mm 4-ply · 20 t	20000	16000	40000	28000	20000	28000	22400	20000	16000
300 mm 4-ply thick · 24 t	24000	19200	48000	33600	24000	33600	26880	24000	19200
600 mm 3-ply thick · 30 t	30000	24000	60000	42000	30000	42000	33600	30000	24000

HOW TO ORDER

- ◆ 01 · Consider the type of sling to be used for suitability.
- ◆ 02 · Calculate the required weight and length for the lifting use.
- ◆ 03 · Select appropriate lifting accessories to minimise damage.
- ◆ 04 · Consider the limitations of the lifting area.

WARNINGS & RECOMMENDATIONS

- ◆ Use according to the actual working load limit.
- ◆ The safety factor is an allowance for emergencies — never lift on it.
- ◆ This webbing elongates 3–5%; allow for it in tight areas.
- ◆ Use according to proper operating principles to reduce the risk of accidents.

03 — POLYESTER SLING · TYPE B

POLYESTER ROUND SLING

Endless polyester round sling with a two-ply woven heavy-duty sleeve, working load limit 1–50 tonnes. The load-bearing core yarns run endlessly inside a double-layer seamless cover — if the sleeve is cut, the damage shows before the core is compromised.

TECHNICAL SPECIFICATIONS

- ◆ Constructed of 100% polyester.
- ◆ Certified standard EN 1492-2.
- ◆ Safety factor 7 : 1.
- ◆ Each working load has its own colour code.
- ◆ Load-bearing yarns protected by a double-layer seamless polyester cover.
- ◆ Elongation 3–5%.
- ◆ Norms: according to Machine Directive 89/392/EC.

ADVANTAGES

- ◆ Extremely flexible — conforms to any load shape.
- ◆ Light, soft and easy to handle; will not mar finishes.
- ◆ Endless core spreads wear over the whole length.
- ◆ Protective sleeve is a built-in visual damage indicator.
- ◆ Colour-coded capacity, 1–50 t.
- ◆ Excellent strength-to-weight ratio.



COLOUR = CAPACITY

HOW TO ORDER

(1) Select the type — endless or eye-and-eye. (2) Check size & length carefully: a round sling ordered at 2 m has a 4 m circumference. (3) The sling can be fitted with accessories as required for the lift. Take care not to damage the sleeve or drag the sling across rough surfaces; if the sleeve is damaged, send it for repair before re-use.

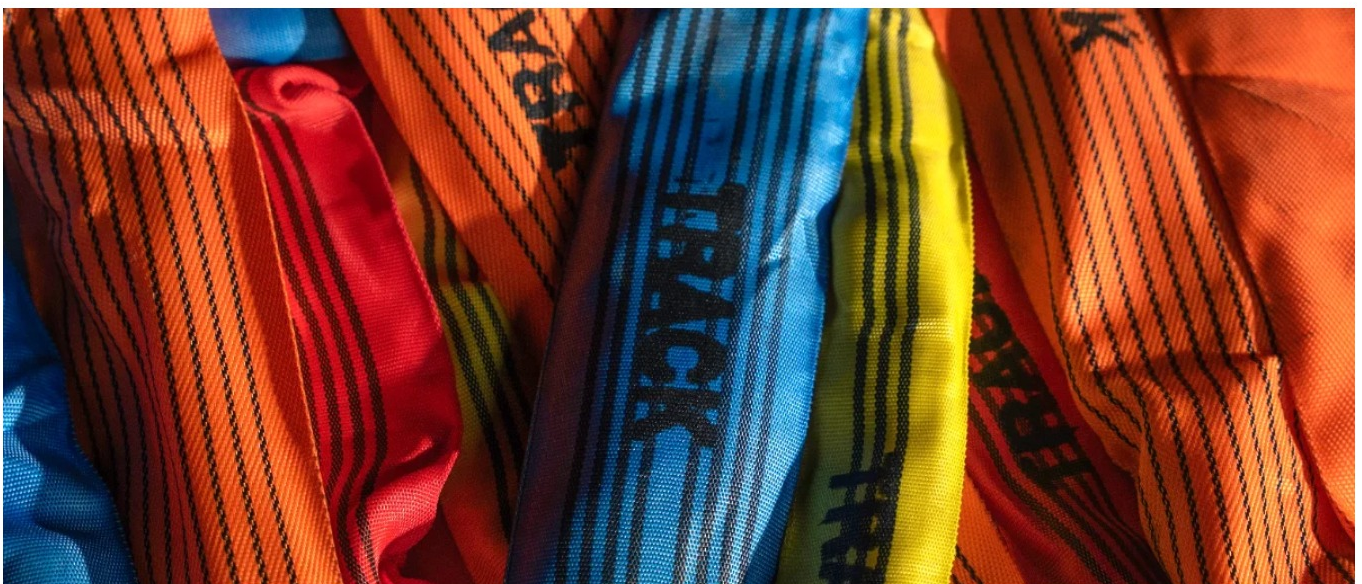

03 — POLYESTER SLING · TYPE B

ROUND SLING — WORKING LOAD LIMIT CHART

Working load limits for TRACK endless polyester round slings to EN 1492-2, from 1 to 50 tonnes, colour-coded by capacity. Values in kilograms; each mode factor is shown in the column head.

POLYESTER ROUND SLING — WLL (KG) BY HITCH & CONFIGURATION

CODE · WLL	STRAIGHT *1.0	CHOKED *0.8	BASKET *2.0	BASKET 7- 45° *1.4	BASKET 45- 60° *1.0	CHK BSKT *0.7	CHK BSKT *0.5	2-SLING ≤45° *1.4	2-SLING CHK *1.12	2-SLING 45- 60° *1.0	2-SLING CHK *0.8
RS-10 · 1 t	1000	800	2000	1400	1000	700	500	1400	1120	1000	800
RS-20 · 2 t	2000	1600	4000	2800	2000	1400	1000	2800	2240	2000	1600
RS-30 · 3 t	3000	2400	6000	4200	3000	2100	1500	4200	3360	3000	2400
RS-40 · 4 t	4000	3200	8000	5600	4000	2800	2000	5600	4480	4000	3200
RS-50 · 5 t	5000	4000	10000	7000	5000	3500	2500	7000	5600	5000	4000
RS-60 · 6 t	6000	4800	12000	8400	6000	4200	3000	8400	6720	6000	4800
RS-80 · 8 t	8000	6400	16000	11200	8000	5600	4000	11200	8960	8000	6400
RS-100 · 10 t	10000	8000	20000	14000	10000	7000	5000	14000	11200	10000	8000
RS-120 · 12 t	12000	9600	24000	16800	12000	8400	6000	16800	13440	12000	9600
RS-150 · 15 t	15000	12000	30000	21000	15000	10500	7500	21000	16800	15000	12000
RS-200 · 20 t	20000	16000	40000	28000	20000	14000	10000	28000	22400	20000	16000
RS-250 · 25 t	25000	20000	50000	35000	25000	17500	12500	35000	28000	25000	20000
RS-300 · 30 t	30000	24000	60000	42000	30000	21000	15000	42000	33600	30000	24000
RS-400 · 40 t	40000	32000	80000	56000	40000	28000	20000	56000	44800	40000	32000
RS-500 · 50 t	50000	40000	100000	70000	50000	35000	25000	70000	56000	50000	40000

Mode factors per EN 1492-2: straight 1.0 · choked 0.8 · parallel basket 2.0 · basket 7–45° 1.4 · basket 45–60° 1.0 · choked basket 0.7 / 0.5 · two-sling ≤45° 1.4 / choked 1.12 · two-sling 45–60° 1.0 / choked 0.8. Safety factor 7:1. Working temperature –40 °C to +100 °C. The sleeve protects the core — retire the sling if core yarns are exposed.

03 — POLYESTER SLING · TYPE C

TRACK RATCHET STRAP WITH CUSTOM HOOK

TRACK ratchet straps secure cargo on truck, rail and sea to EN 12195-2. The buckle is 100% aluminium and the strap 100% polyester — light, handy, low-strain and wear-resistant for a long service life. Choose the width by the load to be restrained.

RATCHET STRAP WITH CUSTOM HOOK — WORKING LOAD CHART

WIDTH	COLOUR	WORKING LOAD	SUITABLE FOR
1"	Yellow / Orange	0.5 – 1 t	Transporting goods on a motorcycle or moving small items
1.5"	Orange	3 t	Transporting steel and small roofing materials
2"	Yellow / Orange	5 – 6 t	Transporting & handling small-to-medium steel coils and general loads
3"	Orange	10 t	Handling large items such as drilling machinery or industrial molds
4"	Orange	12 t	Handling heavy loads incl. very large items such as wind-turbine blades

LASHING CAPACITY & TENSION (EN 12195-2)

LASHING CAPACITY (LC) · STANDARD TENSION FORCE (STF) · STANDARD HAND FORCE (SHF)

STRAP WIDTH	LC — LASHING CAPACITY	STF — PRE-TENSION	SHF — HAND FORCE	ELONGATION @ LC
1" · 25 mm	750 daN	200 daN	50 daN	< 7 %
1.5" · 35 mm	1500 daN	300 daN	50 daN	< 7 %
2" · 50 mm	2500 daN	350 daN	50 daN	< 7 %
3" · 75 mm	5000 daN	400 daN	50 daN	< 7 %
4" · 100 mm	5000 daN	500 daN	50 daN	< 7 %

LC is the rated restraint capacity on the label; STF is the hand pre-tension; SHF the assumed 50 daN hand force. 1 daN ≈ 1.02 kgf. Always read the strap's own certified label.

CONSTRUCTION & CUSTOM HOOKS

TECHNICAL SPECIFICATIONS

- ◆ Strap woven from 100% polyester yarn.
- ◆ Ratchet buckle 100% aluminium — light and corrosion-free.
- ◆ Certified to EN 12195-2; working temp -40 °C to +100 °C.
- ◆ Low elongation (< 7% at LC) for a secure, stable hold.
- ◆ Double-stitched, bar-tacked load-bearing seams.
- ◆ Wear- and UV-resistant edge; colour-coded orange, 1"–4".

CUSTOM HOOK OPTIONS

- ◆ Claw / delta hook — hooks over rope rails and anchor points.
- ◆ S-hook and snap hook — quick attach for light loads.
- ◆ Flat / wire hook — for container and trailer rings.
- ◆ Double-J hook — wraps a flange or lip securely.
- ◆ End-fitting and length made to the application.

LASHING IS NOT LIFTING

Ratchet straps are rated for cargo restraint to EN 12195-2 — tension only with the lever (never a bar), protect against sharp edges, use enough lashings that the combined LC restrains the load, and never use a strap to lift. Inspect webbing, stitching and hook before every use; retire any cut, frayed, burned or knotted strap.

03 — POLYESTER SLING

WHY CHOOSE POLYESTER

Steel rope and polyester each have their place. Where the load is delicate, the surface is finished, the lift is light-to-medium and the handler often works alone, polyester wins on weight, safety and care of the load.

POLYESTER VS. STEEL

PROPERTY	POLYESTER SLING	WIRE ROPE SLING
Weight	Very light — one-person handling	Heavy
Load surface	Gentle — no marring	Can mark / score
Flexibility	Conforms to any shape	Stiff, holds form
Elongation	3–5% — cushions load	< 1% — rigid
Cut / abrasion	Sensitive — use protection	Highly resistant
Temperature	–40 to +100 °C	To > 200 °C
Chemical	Resists acids; weak to alkalis	Resists most; corrodes wet
Safety factor	7 : 1	5 : 1
Inspection	Visual, fast, sleeve indicator	Broken-wire counting

CHOOSE POLYESTER WHEN

- ◆ The load has a painted, machined or fragile finish.
- ◆ Lifts are light-to-medium and frequent.
- ◆ One person must rig the lift alone.
- ◆ The load shape is irregular and needs a conforming sling.

CHOOSE WIRE ROPE WHEN

- ◆ Edges are sharp and unprotected.
- ◆ Temperatures exceed 100 °C.
- ◆ The duty is severe, abrasive or continuous.
- ◆ Maximum capacity in minimum diameter is needed.

BEST OF BOTH

Most worksites carry both. Our engineering team will specify the right mix of wire-rope and polyester slings for your equipment and duty cycle — and certify every piece.





04

RIGGING EQUIPMENT

The hardware between the rope and the load — shackles, hooks, master links and terminations, every size with full engineering dimensions.

ANCHOR & CHAIN SHACKLES

EYE HOOKS

MASTER LINKS

WIRE ROPE CLIPS

WEDGE & SPELTER SOCKETS

ALLOY CHAIN G80/100

04 — RIGGING EQUIPMENT

BOLT-TYPE ANCHOR SHACKLE - TYPE 2130

Forged, quenched & tempered alloy bow shackle with a bolt, nut and cotter pin — the connection that stays secure under vibration and long-term or repeated loading. Hot-dip galvanized or self-coloured, individually magnetic-particle inspected, 6:1 design factor to ASME B30.26 and EN 13889. The complete dimensional reference below carries every nominal size from 3/16" to 4".

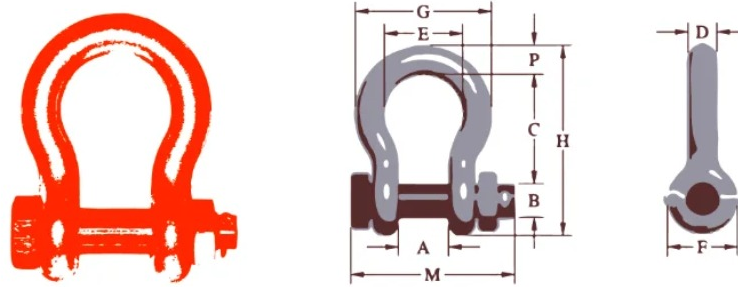

BOLT-TYPE ANCHOR (BOW) SHACKLE — A JAW · B BOW SECTION · C INSIDE LENGTH · D BOLT Ø · E BOW OUTSIDE · F BOLT HEAD · G EYE WIDTH · H OVERALL HEIGHT · M OVERALL WIDTH · P EYE THICKNESS

BOLT-TYPE ANCHOR SHACKLE — CAPACITY & DIMENSIONS (EACH CELL: INCH OVER MM)

SIZE (IN)	WLL (T)	WT (KG)	A	B	C	D	E	F	G	H	M	P
3/16	1/3	0.03	.38 9.7	.25 6.3	.88 22.4	.19 4.8	.60 15.2	.56 14.2	.98 24.9	1.47 37.3	1.29 32.8	.19 4.8
1/4	1/2	0.05	.47 11.9	.32 8.1	1.13 28.7	.25 6.3	.78 19.8	.62 15.7	1.28 32.5	1.84 46.7	1.56 39.6	.25 6.3
5/16	3/4	0.10	.53 13.5	.38 9.7	1.21 30.7	.31 7.9	.84 21.3	.75 19.0	1.46 37.1	2.09 53.1	1.82 46.2	.31 7.9
3/8	1	0.15	.66 16.8	.44 11.2	1.45 36.8	.38 9.7	1.03 26.2	.92 23.4	1.79 45.5	2.50 63.5	2.17 55.1	.38 9.7
7/16	1-1/2	0.22	.75 19.0	.50 12.7	1.69 42.9	.44 11.2	1.16 29.5	1.06 26.9	2.04 51.8	2.91 73.9	2.51 63.8	.44 11.2
1/2	2	0.36	.81 20.6	.64 16.3	1.88 47.8	.50 12.7	1.31 33.3	1.18 30.0	2.31 58.7	3.28 83.3	2.80 71.1	.50 12.7
5/8	3-1/4	0.76	1.06 26.9	.77 19.6	2.38 60.5	.62 15.7	1.69 42.9	1.50 38.1	2.93 74.4	4.19 106	3.56 90.4	.69 17.5
3/4	4-3/4	1.23	1.25 31.8	.90 22.9	2.81 71.4	.75 19.0	2.00 50.8	1.81 46.0	3.50 88.9	4.97 126	4.15 105	.81 20.6
7/8	6-1/2	1.79	1.44 36.6	1.02 25.9	3.31 84.1	.88 22.4	2.28 57.9	2.10 53.3	4.04 103	5.83 148	4.82 122	.97 24.6
1	8-1/2	2.57	1.69 42.9	1.15 29.2	3.76 95.5	1.00 25.4	2.69 68.3	2.38 60.5	4.69 119	6.56 167	5.39 137	1.06 26.9
1-1/8	9-1/2	3.75	1.81 46.0	1.25 31.8	4.27 108	1.16 29.5	2.91 73.9	2.68 68.1	5.15 131	7.47 190	5.90 150	1.25 31.8
1-1/4	12	5.31	2.03 51.6	1.41 35.8	4.69 119	1.29 32.8	3.26 82.8	3.00 76.2	5.76 146	8.26 210	6.69 170	1.38 35.1
1-3/8	13-1/2	7.18	2.25 57.1	1.53 38.9	5.22 133	1.42 36.1	3.62 91.9	3.31 84.1	6.38 162	9.16 233	7.21 183	1.50 38.1
1-1/2	17	8.62	2.38 60.5	1.66 42.2	5.76 146	1.53 38.9	3.88 98.6	3.62 91.9	6.94 176	10.00 254	7.73 196	1.62 41.1
1-3/4	25	15.4	2.88 73.2	2.03 51.6	7.00 178	1.84 46.7	5.00 127	4.19 106	8.80 224	12.34 313	9.63 245	2.25 57.1
2	35	23.7	3.25 82.5	2.31 58.7	7.75 197	2.08 52.8	5.75 146	4.81 122	10.15 258	13.69 348	10.77 274	2.40 61.0
2-1/2	55	44.6	4.12 105	2.81 71.4	10.51 267	2.72 69.1	7.25 184	5.81 148	12.75 324	17.92 455	13.53 344	3.13 79.5
3	85	69.9	5.00 127	3.30 83.8	13.00 330	3.12 79.2	7.88 200	6.50 165	14.62 371	21.50 546	15.13 384	3.63 92.2
3-1/2	120	120	5.25 133	3.76 95.5	14.63 372	3.63 92.2	9.00 229	8.00 203	17.02 432	24.88 632	17.00 432	4.38 111
4	150	153	5.50 140	4.26 108	14.50 368	4.00 102	10.00 254	9.00 229	18.00 457	25.68 652	18.00 457	4.56 116

Design factor 6:1 · max. proof load 2× WLL. Tolerance A ±.06-.25, C ±.06-.25 in. Fitted with bolt, nut & cotter. Sizes 85 t and above individually proof-tested with certificate. Reference dimensions for fit-up — verify against the test certificate.

04 — RIGGING EQUIPMENT

SCREW-PIN ANCHOR SHACKLE - TYPE 209

The field rigger’s standard bow shackle for non-permanent connections — quick to fit and remove, forged and quenched & tempered with an alloy screw pin, 6:1 design factor to ASME B30.26. Choose the bolt-type (Type 2130) wherever the pin can roll and unscrew under vibration or sustained load.

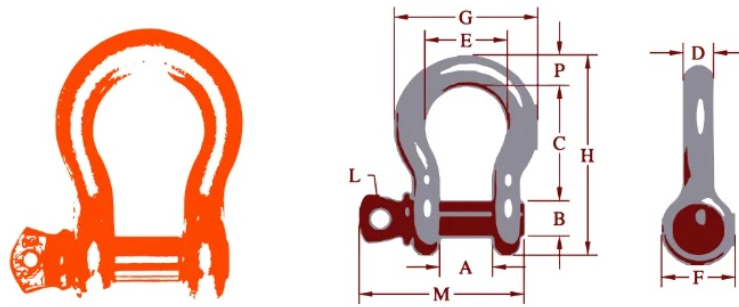

SCREW-PIN ANCHOR (BOW) SHACKLE — A JAW · B BOW SECTION · C INSIDE LENGTH · D PIN Ø · E BOW OUTSIDE · F PIN HEAD · G EYE WIDTH · H OVERALL HEIGHT · L PIN TAIL · M OVERALL WIDTH · P EYE THICKNESS

SCREW-PIN ANCHOR SHACKLE — CAPACITY & DIMENSIONS (EACH CELL: INCH OVER MM)

SIZE (IN)	WLL (T)	WT (KG)	A	B	C	D	E	F	G	H	L	M	P
3/16	1/3	0.03	.38 9.7	.25 6.3	.88 22.4	.19 4.8	.60 15.2	.56 14.2	.98 24.9	1.47 37.3	.16 4.1	1.14 29.0	.19 4.8
1/4	1/2	0.05	.47 11.9	.32 8.1	1.13 28.7	.25 6.3	.78 19.8	.62 15.7	1.28 32.5	1.84 46.7	.19 4.8	1.43 36.3	.25 6.3
5/16	3/4	0.08	.53 13.5	.38 9.7	1.21 30.7	.31 7.9	.84 21.3	.75 19.0	1.46 37.1	2.09 53.1	.22 5.6	1.71 43.4	.31 7.9
3/8	1	0.14	.66 16.8	.44 11.2	1.45 36.8	.38 9.7	1.03 26.2	.92 23.4	1.79 45.5	2.50 63.5	.25 6.3	2.06 52.3	.38 9.7
7/16	1-1/2	0.17	.75 19.0	.50 12.7	1.69 42.9	.44 11.2	1.16 29.5	1.06 26.9	2.04 51.8	2.91 73.9	.31 7.9	2.37 60.2	.44 11.2
1/2	2	0.33	.81 20.6	.63 16.0	1.88 47.8	.50 12.7	1.31 33.3	1.18 30.0	2.31 58.7	3.28 83.3	.38 9.7	2.69 68.3	.50 12.7
5/8	3-1/4	0.62	1.06 26.9	.75 19.0	2.38 60.5	.62 15.7	1.69 42.9	1.50 38.1	2.93 74.4	4.19 106	.44 11.2	3.34 84.8	.69 17.5
3/4	4-3/4	1.07	1.25 31.8	.88 22.4	2.81 71.4	.75 19.0	2.00 50.8	1.81 46.0	3.50 88.9	4.97 126	.50 12.7	3.97 101	.81 20.6
7/8	6-1/2	1.64	1.44 36.6	1.00 25.4	3.31 84.1	.88 22.4	2.28 57.9	2.10 53.3	4.04 103	5.83 148	.50 12.7	4.50 114	.97 24.6
1	8-1/2	2.28	1.69 42.9	1.16 29.5	3.76 95.5	1.00 25.4	2.69 68.3	2.38 60.5	4.69 119	6.56 167	.56 14.2	5.13 130	1.06 26.9
1-1/8	9-1/2	3.36	1.81 46.0	1.25 31.8	4.27 108	1.16 29.5	2.91 73.9	2.68 68.1	5.15 131	7.47 190	.63 16.0	5.97 152	1.25 31.8
1-1/4	12	4.31	2.03 51.6	1.41 35.8	4.69 119	1.29 32.8	3.26 82.8	3.00 76.2	5.76 146	8.26 210	.69 17.5	6.50 165	1.38 35.1
1-3/8	13-1/2	6.14	2.25 57.1	1.56 39.6	5.22 133	1.42 36.1	3.62 91.9	3.31 84.1	6.38 162	9.16 233	.75 19.0	6.93 176	1.50 38.1
1-1/2	17	7.80	2.38 60.5	1.66 42.2	5.76 146	1.53 38.9	3.88 98.6	3.62 91.9	6.94 176	10.00 254	.81 20.6	7.43 189	1.62 41.1
1-3/4	25	14.0	2.88 73.2	2.03 51.6	7.00 178	1.84 46.7	5.00 127	4.19 106	8.80 224	12.34 313	1.00 25.4	9.19 233	2.25 57.1
2	35	20.4	3.25 82.5	2.28 57.9	7.75 197	2.08 52.8	5.75 146	4.81 122	10.15 258	13.68 347	1.13 28.7	10.36 263	2.40 61.0
2-1/2	55	38.9	4.12 105	2.78 70.6	10.51 267	2.72 69.1	7.25 184	5.81 148	12.75 324	17.92 455	1.38 35.1	13.17 335	3.13 79.5

Design factor 6:1 · max. proof load 2× WLL. Tolerance A ±.06—.25, C ±.06—.25 in. Galvanized or self-coloured. Do not use a screw-pin shackle where the pin can rotate and back out under load. Reference dimensions — verify against the test certificate.

04 — RIGGING EQUIPMENT

BOLT-TYPE CHAIN (D) SHACKLE - TYPE 2150

The straight-sided D-shackle for in-line tension — narrower jaw and bow than an anchor shackle, for a single sling leg or chain end. Forged, quenched & tempered, bolt-nut-cotter pin, 6:1 design factor to ASME B30.26; sizes ½–25 t meet EN 13889. Hot-dip galvanized; sizes 85 t individually proof-tested.

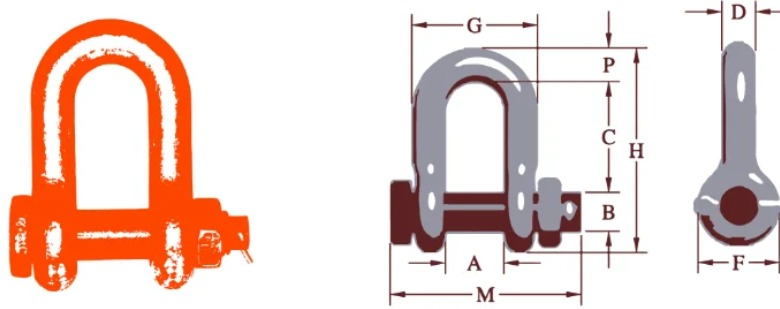

BOLT-TYPE CHAIN (D) SHACKLE — A JAW · B BOW SECTION · C INSIDE LENGTH · D BOLT Ø · F BOLT HEAD · G EYE WIDTH · H OVERALL HEIGHT · M OVERALL WIDTH · P EYE THICKNESS

BOLT-TYPE CHAIN SHACKLE — CAPACITY & DIMENSIONS (EACH CELL: INCH OVER MM)

SIZE (IN)	WLL (T)	WT (KG)	A	B	C	D	F	G	H	M	P
1/4	1/2	0.06	.47 11.9	.32 8.1	.97 24.6	.25 6.3	.62 15.7	.97 24.6	1.59 40.4	1.56 39.6	.25 6.3
5/16	3/4	0.10	.53 13.5	.38 9.7	1.15 29.2	.31 7.9	.75 19.0	1.15 29.2	1.91 48.5	1.82 46.2	.31 7.9
3/8	1	0.15	.66 16.8	.44 11.2	1.42 36.1	.38 9.7	.92 23.4	1.42 36.1	2.31 58.7	2.17 55.1	.38 9.7
7/16	1-1/2	0.22	.75 19.0	.50 12.7	1.63 41.4	.44 11.2	1.06 26.9	1.63 41.4	2.67 67.8	2.51 63.8	.44 11.2
1/2	2	0.34	.81 20.6	.64 16.3	1.81 46.0	.50 12.7	1.18 30.0	1.81 46.0	3.03 77.0	2.80 71.1	.50 12.7
5/8	3-1/4	0.67	1.06 26.9	.77 19.6	2.32 58.9	.63 16.0	1.50 38.1	2.32 58.9	3.76 95.5	3.56 90.4	.63 16.0
3/4	4-3/4	1.14	1.25 31.8	.90 22.9	2.75 69.8	.75 19.0	1.81 46.0	2.75 69.8	4.53 115	4.15 105	.81 20.6
7/8	6-1/2	1.75	1.44 36.6	1.02 25.9	3.20 81.3	.88 22.4	2.10 53.3	3.20 81.3	5.33 135	4.82 122	.97 24.6
1	8-1/2	2.52	1.69 42.9	1.15 29.2	3.69 93.7	1.00 25.4	2.38 60.5	3.69 93.7	5.94 151	5.39 137	1.00 25.4
1-1/8	9-1/2	3.45	1.81 46.0	1.25 31.8	4.07 103	1.13 28.7	2.68 68.1	4.07 103	6.78 172	5.90 150	1.25 31.8
1-1/4	12	4.90	2.03 51.6	1.41 35.8	4.53 115	1.25 31.8	3.00 76.2	4.53 115	7.50 191	6.69 170	1.38 35.1
1-3/8	13-1/2	6.24	2.25 57.1	1.53 38.9	5.01 127	1.38 35.1	3.31 84.1	5.01 127	8.28 210	7.21 183	1.50 38.1
1-1/2	17	7.72	2.38 60.5	1.66 42.2	5.38 137	1.50 38.1	3.62 91.9	5.38 137	9.05 230	7.73 196	1.62 41.1
1-3/4	25	14.2	2.88 73.2	2.03 51.6	6.38 162	1.75 44.4	4.19 106	6.38 162	10.97 279	9.63 245	2.12 53.8
2	35	21.2	3.25 82.5	2.31 58.7	7.25 184	2.10 53.3	5.00 127	7.25 184	12.74 324	10.77 274	2.36 59.9
2-1/2	55	38.6	4.12 105	2.81 71.4	9.38 238	2.63 66.8	5.68 144	9.38 238	14.85 377	13.53 344	2.63 66.8
3	85	56.4	5.00 127	3.30 83.8	11.00 279	3.00 76.2	6.50 165	11.00 279	16.87 428	15.13 384	3.50 88.9

Design factor 6:1 · max. proof load 2× WLL. Tolerance A ±.06–.25, C ±.06–.25 in. Fitted with bolt, nut & cotter. The narrow D-bow suits single-leg in-line loads — do not side-load. Reference dimensions — verify against the test certificate.

04 — RIGGING EQUIPMENT

SCREW-PIN CHAIN (D) SHACKLE - TYPE 210

The screw-pin D-shackle — a quick-release straight-bow shackle for single-leg, in-line connections. Forged, quenched & tempered with an alloy screw pin, 6:1 design factor to ASME B30.26, galvanized. Use the bolt-type (Type 2150) for permanent or vibrating connections where the pin could unscrew.

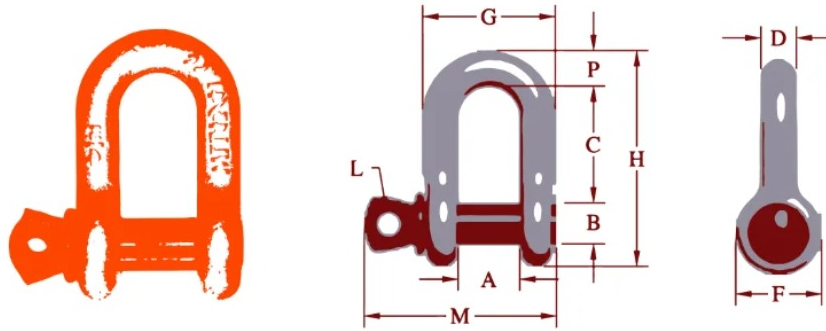

SCREW-PIN CHAIN (D) SHACKLE — A JAW · B BOW SECTION · C INSIDE LENGTH · D PIN Ø · F PIN HEAD · G EYE WIDTH · H OVERALL HEIGHT · L PIN TAIL · M OVERALL WIDTH · P EYE THICKNESS

SCREW-PIN CHAIN SHACKLE — CAPACITY & DIMENSIONS (EACH CELL: INCH OVER MM)

SIZE (IN)	WLL (T)	WT (KG)	A	B	C	D	F	G	H	L	M	P
1/4	1/2	0.05	.47 11.9	.32 8.1	.87 22.1	.25 6.3	.62 15.7	.97 24.6	1.59 40.4	.19 4.8	1.43 36.3	.25 6.3
5/16	3/4	0.08	.53 13.5	.38 9.7	1.04 26.4	.31 7.9	.75 19.0	1.15 29.2	1.91 48.5	.22 5.6	1.71 43.4	.31 7.9
3/8	1	0.13	.66 16.8	.44 11.2	1.25 31.8	.38 9.7	.92 23.4	1.42 36.1	2.31 58.7	.25 6.3	2.06 52.3	.38 9.7
7/16	1-1/2	0.20	.75 19.0	.50 12.7	1.45 36.8	.44 11.2	1.06 26.9	1.63 41.4	2.67 67.8	.31 7.9	2.37 60.2	.44 11.2
1/2	2	0.29	.81 20.6	.63 16.0	1.63 41.4	.50 12.7	1.18 30.0	1.81 46.0	3.03 77.0	.38 9.7	2.69 68.3	.50 12.7
5/8	3-1/4	0.57	1.06 26.9	.75 19.0	2.00 50.8	.63 16.0	1.50 38.1	2.32 58.9	3.76 95.5	.44 11.2	3.34 84.8	.63 16.0
3/4	4-3/4	1.03	1.25 31.8	.88 22.4	2.38 60.5	.75 19.0	1.81 46.0	2.75 69.8	4.53 115	.50 12.7	3.97 101	.81 20.6
7/8	6-1/2	1.43	1.44 36.6	1.00 25.4	2.81 71.4	.88 22.4	2.10 53.3	3.20 81.3	5.33 135	.50 12.7	4.50 114	.97 24.6
1	8-1/2	2.15	1.69 42.9	1.16 29.5	3.19 81.0	1.00 25.4	2.38 60.5	3.69 93.7	5.94 151	.56 14.2	5.13 130	1.00 25.4
1-1/8	9-1/2	3.06	1.81 46.0	1.25 31.8	3.56 90.4	1.13 28.7	2.68 68.1	4.07 103	6.78 172	.63 16.0	5.97 152	1.25 31.8
1-1/4	12	4.11	2.03 51.6	1.41 35.8	3.93 99.8	1.25 31.8	3.00 76.2	4.53 115	7.50 191	.69 17.5	6.50 165	1.38 35.1
1-3/8	13-1/2	5.28	2.25 57.1	1.56 39.6	4.36 111	1.38 35.1	3.31 84.1	5.01 127	8.28 210	.75 19.0	6.93 176	1.50 38.1
1-1/2	17	7.23	2.38 60.5	1.66 42.2	4.87 124	1.50 38.1	3.62 91.9	5.38 137	9.05 230	.81 20.6	7.43 189	1.62 41.1
1-3/4	25	12.1	2.88 73.2	2.03 51.6	5.76 146	1.75 44.4	4.19 106	6.38 162	10.97 279	1.00 25.4	9.19 233	2.12 53.8
2	35	19.2	3.25 82.5	2.28 57.9	6.75 171	2.10 53.3	5.00 127	7.25 184	12.74 324	1.13 28.7	10.36 263	2.36 59.9
2-1/2	55	32.5	4.12 105	2.78 70.6	8.00 203	2.63 66.8	5.68 144	9.38 238	14.85 377	1.38 35.1	13.17 335	2.63 66.8

Design factor 6:1 · max. proof load 2× WLL. Tolerance A ±.06–.25, C ±.06–.25 in. The narrow D-bow suits single-leg in-line loads — do not side-load. Reference dimensions — verify against the test certificate.

04 — RIGGING EQUIPMENT

WELDED MASTER LINK - TYPE 344

Grade 80 alloy welded master link — quenched & tempered and individually proof-tested to the value shown, each link marked with a product-identification code (PIC) for full material traceability. The single master link gathers one- and two-leg slings onto the crane hook; an engineered flat (G) on the smaller sizes seats the S-1325A coupler link. DNV 2.7-1 type-approved for offshore containers, and fatigue-rated to 20,000 cycles at 1.5× the working load limit.

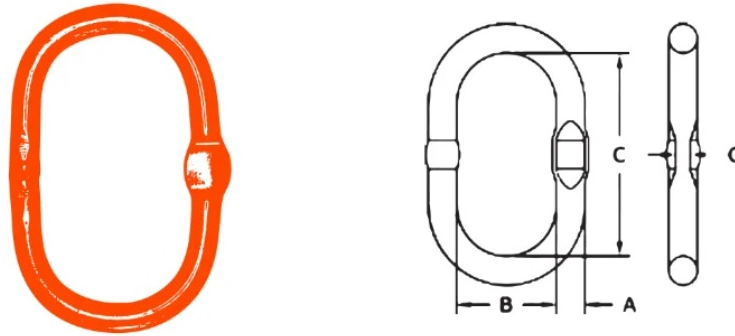

WELDED MASTER LINK (TYPE 344) — A MATERIAL Ø · B INSIDE WIDTH · C INSIDE LENGTH · G ENGINEERED FLAT FOR THE COUPLER LINK

WELDED MASTER LINK (TYPE 344), GRADE 80 — CAPACITY & DIMENSIONS (EACH DIMENSION CELL: INCH OVER MM)

G80 CHAIN	G100 CHAIN	WLL (T)	PROOF (KN)	A	B	C	G
6mm, 9/32	6mm, 9/32	3.2	78	0.51 13.0	2.36 59.9	4.72 120	0.26 6.6
5/16, 3/8	5/16, 3/8	4.1	101	0.67 17.0	3.54 89.9	6.30 160	0.33 8.4
3/8, 1/2	3/8, 1/2	6.7	165	0.75 19.0	3.54 89.9	6.30 160	0.33 8.4
3/8, 1/2	3/8, 1/2	7.0	172	0.87 22.1	5.71 145	10.83 275	0.41 10.4
5/8	3/8, 1/2	8.8	216	0.87 22.1	3.94 100	7.09 180	0.41 10.4
1/2, 5/8	1/2	8.9	218	0.98 24.9	5.71 145	10.83 275	0.53 13.5
5/8	5/8, 1/2	11.5	282	0.98 24.9	4.53 115	8.27 210	0.53 13.5
5/8	5/8, 1/2	13.0	319	1.10 27.9	5.71 145	10.83 275	0.53 13.5
3/4	5/8, 3/4	17.0	417	1.26 32.0	5.71 145	10.83 275	0.66 16.8
3/4, 7/8	3/4	24.0	588	1.42 36.1	6.10 155	11.22 285	-
7/8	7/8	31.5	773	1.57 39.9	5.51 140	10.63 270	-
1	1	38.3	938	1.77 45.0	7.09 180	13.39 340	-
1	1, 1-1/4	45.0	1103	2.01 51.1	8.46 215	15.35 390	-
1-1/4	1-1/4	67.0	1642	2.17 55.1	7.99 203	15.98 406	-

WLL shown for single- and two-leg use to 45°. Proof load is the figure each link is individually tested to, with certificate. Engineered flat (G) on links up to 1-7/32" accepts the S-1325A coupler link; the two largest sizes have no manufactured flat. For three- and four-leg slings use the Type 347 assembly on the next page.

SPECIFICATION

- ◆ Grade 80 alloy steel, quenched & tempered.
- ◆ Individually proof-tested to ~2.5× WLL, certified.
- ◆ PIC marking — grade, size, CE & traceability code.
- ◆ Proof-tested with 70% inside-width fixtures per EN 1677.
- ◆ Fatigue-rated to 20,000 cycles at 1.5× WLL.

ONE LINK, ONE & TWO LEGS

The Type 344 is the gather point for single- and two-leg slings — sized so the master-link inside width seats correctly on the crane hook while the engineered flat keeps the coupler link from point-loading. Step up to the Type 347 assembly the moment a third leg is added.

04 — RIGGING EQUIPMENT

MASTER LINK ASSEMBLY - TYPE 347

Grade 80 alloy welded master-link assembly — one master link plus two intermediate links — for three- and four-leg slings. The master takes the crane hook while each intermediate link carries two sling legs. 100% proof-tested and every batch impact-tested; the master is marked with a PIC and each sub-link with its own traceability code. DNV 2.7-1 type-approved sets available for offshore containers.

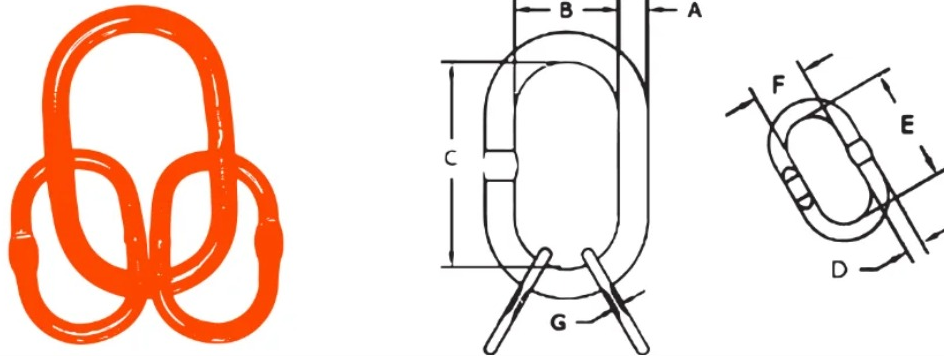

MASTER-LINK ASSEMBLY (TYPE 347) — A/B/C MASTER LINK (MATERIAL Ø · INSIDE WIDTH · INSIDE LENGTH) · D/E/F INTERMEDIATE LINK · G ENGINEERED FLAT FOR THE COUPLER LINK

MASTER-LINK ASSEMBLY (TYPE 347), GRADE 80 — CAPACITY & DIMENSIONS (EACH DIMENSION CELL: INCH OVER MM)

G80 3-4 LEG	WLL (T)	PROOF (KN)	A	B	C	D	E	F	G
6mm	3.2	78	0.51 13.0	2.36 59.9	4.72 120	0.51 13.0	4.72 120	2.36 59.9	0.26 6.6
6mm, 9/32	4.1	101	0.67 17.0	3.54 89.9	6.30 160	0.51 13.0	4.72 120	2.36 59.9	0.26 6.6
9/32	4.2	104	0.75 19.0	3.54 89.9	6.30 160	0.51 13.0	4.72 120	2.36 59.9	0.26 6.6
5/16	7.0	172	0.87 22.1	3.94 100	7.09 180	0.67 17.0	6.30 160	3.54 89.9	0.33 8.4
5/16	7.0	172	0.87 22.1	5.71 145	10.83 275	0.67 17.0	6.30 160	3.54 89.9	0.33 8.4
3/8	8.5	208	0.87 22.1	3.94 100	7.09 180	0.75 19.0	6.30 160	3.54 89.9	0.33 8.4
3/8	8.9	219	0.98 24.9	4.53 115	8.27 210	0.75 19.0	6.30 160	3.54 89.9	0.33 8.4
3/8	8.9	219	0.98 24.9	5.71 145	10.83 275	0.75 19.0	6.30 160	3.54 89.9	0.33 8.4
1/2	14.5	356	1.10 27.9	5.71 145	10.83 275	0.87 22.1	7.09 180	3.94 100	0.41 10.4
1/2	17.0	417	1.26 32.0	5.71 145	10.83 275	0.98 24.9	8.27 210	4.53 115	0.53 13.5
5/8	23.6	578	1.42 36.1	6.10 155	11.22 285	1.10 27.9	7.48 190	4.33 110	0.53 13.5
5/8	28.1	689	1.57 39.9	5.51 140	10.63 270	1.26 32.0	10.83 275	5.71 145	0.66 16.8
3/4	38.3	939	1.77 45.0	7.09 180	13.39 340	1.42 36.1	11.22 285	6.10 155	-
7/8	45.0	1103	2.01 51.1	8.46 215	15.35 390	1.57 39.9	10.63 270	5.51 140	-
1	67.0	1642	2.17 55.1	7.99 203	15.98 406	2.01 51.1	15.35 390	8.46 215	-

WLL shown for three- and four-leg use to 45°. A/B/C are the master-link material Ø, inside width and inside length; D/E/F the intermediate-link material Ø, inside width and inside length; G the engineered flat for the coupler link. Proof load individually certified. Links over 1-1/4" (32 mm) have no manufactured flat.

04 — RIGGING EQUIPMENT

WIRE ROPE CLIP · U-BOLT · TYPE 450

Forged-base U-bolt clip for field-formed wire-rope eyes and terminations — galvanized, with a forged saddle on the live (load) side of the rope. Efficiency 80% for 1/8"–7/8" ropes and 90% for 1"–3-1/2". Always fit the saddle on the live end and the U-bolt on the dead end — “never saddle a dead horse.”

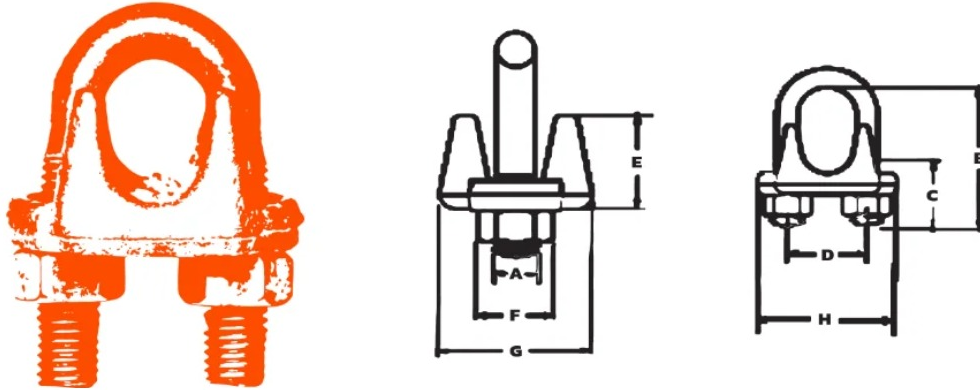

U-BOLT CLIP — A BOLT Ø · B BASE HEIGHT · C SADDLE WIDTH · D BOLT CENTRES · E OVERALL HEIGHT · F U-BOLT GAP · G SADDLE BASE · H BASE WIDTH

WIRE ROPE CLIP (U-BOLT) — DIMENSIONS BY ROPE SIZE (EACH CELL: INCH OVER MM)

ROPE (IN)	ROPE (MM)	A	B	C	D	E	F	G	H
1/8	3–4	.22 5.6	.72 18.3	.44 11.2	.47 11.9	.37 9.4	.38 9.7	.81 20.6	.99 25.1
3/16	5	.25 6.3	.97 24.6	.56 14.2	.59 15.0	.50 12.7	.44 11.2	.94 23.9	1.18 30.0
1/4	6–7	.31 7.9	1.03 26.2	.50 12.7	.75 19.0	.66 16.8	.56 14.2	1.19 30.2	1.43 36.3
5/16	8	.38 9.7	1.38 35.1	.75 19.0	.88 22.4	.73 18.5	.69 17.5	1.31 33.3	1.66 42.2
3/8	9–10	.44 11.2	1.50 38.1	.75 19.0	1.00 25.4	.91 23.1	.75 19.0	1.63 41.4	1.94 49.3
7/16–1/2	11–13	.50 12.7	1.88 47.8	1.00 25.4	1.19 30.2	1.13 28.7	.88 22.4	1.91 48.5	2.28 57.9
9/16–5/8	14–16	.56 14.2	2.25 57.1	1.25 31.8	1.31 33.3	1.34 34.0	.94 23.9	2.06 52.3	2.50 63.5
3/4	18–20	.62 15.7	2.75 69.8	1.44 36.6	1.50 38.1	1.39 35.3	1.06 26.9	2.25 57.1	2.84 72.1
7/8	22	.75 19.0	3.12 79.2	1.62 41.1	1.75 44.4	1.58 40.1	1.25 31.8	2.44 62.0	3.16 80.3
1	24–26	.75 19.0	3.50 88.9	1.81 46.0	1.88 47.8	1.77 45.0	1.25 31.8	2.63 66.8	3.47 88.1
1-1/8	28–30	.75 19.0	3.88 98.6	2.00 50.8	2.00 50.8	1.91 48.5	1.25 31.8	2.81 71.4	3.59 91.2
1-1/4	32–34	.88 22.4	4.44 113	2.22 56.4	2.34 59.4	2.17 55.1	1.44 36.6	3.13 79.5	4.13 105
1-3/8	36	.88 22.4	4.44 113	2.22 56.4	2.34 59.4	2.31 58.7	1.44 36.6	3.13 79.5	4.19 106
1-1/2	38	.88 22.4	4.94 125	2.38 60.5	2.59 65.8	2.44 62.0	1.44 36.6	3.41 86.6	4.44 113
1-5/8	41–42	1.00 25.4	5.31 135	2.62 66.5	2.75 69.8	2.66 67.6	1.63 41.4	3.63 92.2	4.75 121
1-3/4	44–46	1.13 28.7	5.75 146	2.75 69.8	3.06 77.7	2.92 74.2	1.81 46.0	3.81 96.8	5.24 133
2	48–52	1.25 31.8	6.44 164	3.00 76.2	3.38 85.9	3.03 77.0	2.00 50.8	4.44 113	5.88 149
2-1/4	56–58	1.25 31.8	7.13 181	3.19 81.0	3.88 98.6	3.19 81.0	2.00 50.8	4.56 116	6.38 162
2-1/2	62–65	1.25 31.8	7.69 195	3.44 87.4	4.13 105	3.69 93.7	2.00 50.8	4.69 119	6.63 168
3	75–78	1.50 38.1	9.19 233	3.88 98.6	4.75 121	4.44 113	2.38 60.5	5.31 135	7.61 193

Fit the saddle on the live side; space clips ≈ 6× rope Ø apart; turn back the correct tail length and torque the nuts to the rope-size specification, then re-torque after the first load. Number of clips and torque increase with rope diameter — follow the tag supplied with each clip. Efficiency 80% (≤7/8") / 90% (≥1").

04 — RIGGING EQUIPMENT

OPEN SPELTER SOCKET - TYPE 416

The 100%-efficient permanent termination with an open jaw and pin. The rope is broomed out inside the tapered basket and locked with poured resin, developing the full catalogue strength of the rope. Forged steel through 1-1/2" and cast alloy steel 1-5/8" through 4"; cast baskets 1-5/8" and larger are magnetic-particle and ultrasonic inspected. The table below gives the complete technical dimensions for every rope size, inch over millimetre.

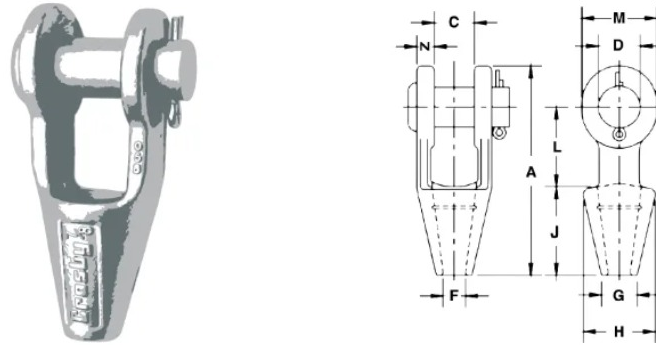

OPEN SPELTER SOCKET — A OVERALL LENGTH · C PIN Ø (± TOL) · D · F · G THROAT · H BASKET OD · J JAW OPENING · L BASKET LENGTH · M · N

OPEN SPELTER SOCKET (TYPE 416) — FULL DIMENSIONS (IN / MM)

ROPE (IN)	(MM)	A	C	C ± TOL	D	F	G	H	J	L	M	N
5/16-3/8	8-10	4.84 123	.81 20.6	.06 1.5	.81 20.6	.50 12.7	.81 20.6	1.69 42.9	2.25 57.1	1.75 44.4	1.50 38.1	.44 11.2
7/16-1/2	11-13	5.56 141	1.00 25.4	.06 1.5	1.00 25.4	.56 14.2	.94 23.9	1.88 47.8	2.50 63.5	2.00 50.8	1.88 47.8	.50 12.7
9/16-5/8	14-16	6.75 171	1.25 31.8	.06 1.5	1.19 30.2	.69 17.5	1.13 28.7	2.25 57.1	3.00 76.2	2.50 63.5	2.25 57.1	.64 16.3
3/4	18	7.94 202	1.50 38.1	.06 1.5	1.38 35.1	.81 20.6	1.25 31.8	2.62 66.5	3.50 88.9	3.00 76.2	2.62 66.5	.62 15.7
7/8	20-22	9.25 235	1.75 44.4	.06 1.5	1.63 41.4	.94 23.9	1.50 38.1	3.25 82.5	4.00 102	3.50 88.9	3.13 79.5	.80 20.3
1	24-26	10.56 268	2.00 50.8	.06 1.5	2.00 50.8	1.13 28.7	1.75 44.4	3.75 95.3	4.50 114	4.00 102	3.75 95.3	.88 22.4
1-1/8	28-30	11.81 300	2.25 57.1	.12 3.0	2.25 57.1	1.25 31.8	2.00 50.8	4.12 105	5.00 127	4.62 117	4.12 105	1.00 25.4
1-1/4-1-3/8	32-35	13.19 335	2.50 63.5	.12 3.0	2.50 63.5	1.50 38.1	2.25 57.1	4.75 121	5.50 140	5.00 127	4.75 121	1.13 28.7
1-1/2	38	15.12 384	3.00 76.2	.12 3.0	2.75 69.8	1.63 41.4	2.75 69.8	5.25 133	6.00 152	6.00 152	5.38 137	1.19 30.2
1-5/8	40-42	16.25 413	3.00 76.2	.12 3.0	3.00 76.2	1.75 44.4	3.00 76.2	5.50 140	6.50 165	6.50 165	5.75 146	1.31 33.3
1-3/4-1-7/8	44-48	18.25 464	3.50 88.9	.12 3.0	3.50 88.9	2.00 50.8	3.13 79.5	6.38 162	7.50 191	7.00 178	6.50 165	1.56 39.6
2-2-1/8	50-54	21.50 546	4.00 102	.12 3.0	3.75 95.3	2.25 57.1	3.75 95.3	7.38 187	8.50 216	9.00 229	7.00 178	1.81 46.0
2-1/4-2-3/8	56-60	23.50 597	4.50 114	.12 3.0	4.25 108	2.50 63.5	4.00 102	8.25 210	9.00 229	10.00 254	7.75 197	2.13 54.1
2-1/2-2-5/8	64-67	25.50 648	5.00 127	.12 3.0	4.75 121	2.88 73.2	4.50 114	9.25 235	9.75 248	10.75 273	8.50 216	2.38 60.5
2-3/4-2-7/8	70-73	27.25 692	5.25 133	.25 6.3	5.00 127	3.12 79.2	4.88 124	10.50 267	11.00 279	11.00 279	9.00 229	2.88 73.2
3-3-1/8	75-80	29.00 737	5.75 146	.25 6.3	5.25 133	3.38 85.9	5.25 133	11.12 282	12.00 305	11.25 286	9.50 241	3.00 76.2
3-1/4-3-3/8	82-86	30.88 784	6.25 159	.25 6.3	5.50 140	3.62 91.9	5.75 146	11.88 302	13.00 330	11.75 298	10.00 254	3.12 79.2
3-1/2-3-5/8	88-92	33.25 845	6.75 171	.25 6.3	6.00 152	3.88 98.6	6.50 165	12.38 314	14.00 356	12.50 318	10.75 273	3.25 82.5
3-3/4-4	94-102	36.25 921	7.50 191	.25 6.3	7.00 178	4.25 108	7.25 184	13.62 346	15.00 381	13.50 343	12.50 318	3.50 88.9

Open grooved sockets meet the performance requirements of Federal Specification RR-S-550F, Type A. Termination efficiency 100% based on catalogue rope strength, for 6x7, 6x19 or 6x37 IPS, EIP, EEIP, RRL, FC or IWRC rope. Strand-cored ropes need basket length ≥ 5x strand Ø or 50x wire Ø, whichever is greater.

04 — RIGGING EQUIPMENT

CLOSED SPELTER SOCKET - TYPE 417

The closed version of the poured permanent termination — the same tapered resin basket, but finishing in a solid forged eye instead of a jaw and pin. A 100%-efficient end fitting for slings and standing rope where a closed eye is preferred. Forged steel through 1-1/2" and cast alloy steel 1-5/8" through 4"; cast baskets 1-5/8" and larger are magnetic-particle and ultrasonic inspected. The table below gives the complete technical dimensions for every rope size, inch over millimetre.

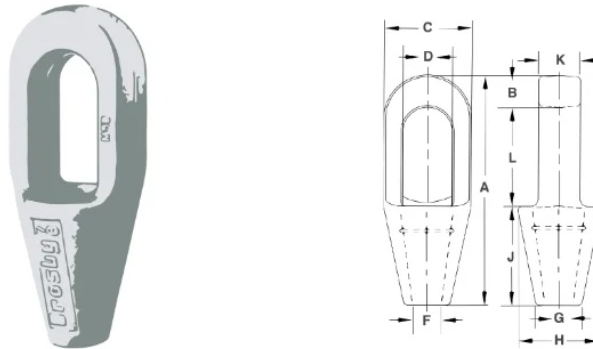

CLOSED SPELTER SOCKET — A OVERALL LENGTH · B EYE THICKNESS · C EYE ID · D · F · G THROAT · H BASKET OD · J · K EYE WIDTH · L BASKET LENGTH

CLOSED SPELTER SOCKET (TYPE 417) — FULL DIMENSIONS (IN / MM)

ROPE (IN)	(MM)	A	B	C	D	F	G	H	J	K	L
5/16-3/8	8-10	4.94 125	.62 15.7	1.69 42.9	.97 24.6	.50 12.7	.81 20.6	1.69 42.9	2.25 57.1	.69 17.5	2.06 52.3
7/16-1/2	11-13	5.50 140	.69 17.5	2.00 50.8	1.16 29.5	.56 14.2	.94 23.9	2.00 50.8	2.50 63.5	.88 22.4	2.31 58.7
9/16-5/8	14-16	6.31 160	.81 20.6	2.63 66.8	1.41 35.8	.69 17.5	1.12 28.4	2.38 60.5	3.00 76.2	1.00 25.4	2.50 63.5
3/4	18	7.62 194	1.06 26.9	3.00 76.2	1.66 42.2	.88 22.4	1.25 31.8	2.75 69.8	3.50 88.9	1.25 31.8	3.06 77.7
7/8	20-22	8.75 222	1.25 31.8	3.63 92.2	1.94 49.3	1.00 25.4	1.50 38.1	3.25 82.5	4.00 102	1.50 38.1	3.50 88.9
1	24-26	9.91 252	1.41 35.8	4.13 105	2.30 58.4	1.13 28.7	1.75 44.4	3.75 95.3	4.50 114	1.75 44.4	4.00 102
1-1/8	28-30	11.00 279	1.50 38.1	4.50 114	2.56 65.0	1.25 31.8	2.00 50.8	4.13 105	5.00 127	2.00 50.8	4.50 114
1-1/4-1-3/8	32-35	12.12 308	1.63 41.4	5.00 127	2.81 71.4	1.50 38.1	2.25 57.1	4.75 121	5.50 140	2.25 57.1	5.00 127
1-1/2	38	13.94 354	1.94 49.3	5.38 137	3.19 81.0	1.63 41.4	2.75 69.8	5.25 133	6.00 152	2.50 63.5	6.00 152
1-5/8	40-42	15.13 384	2.13 54.1	5.75 146	3.25 82.5	1.75 44.4	3.00 76.2	5.50 140	6.50 165	2.75 69.8	6.50 165
1-3/4-1-7/8	44-48	17.25 438	2.19 55.6	6.75 171	3.75 95.3	2.00 50.8	3.13 79.5	6.38 162	7.50 191	3.00 76.2	7.56 192
2-2-1/8	50-54	19.87 505	2.44 62.0	7.63 194	4.38 111	2.25 57.1	3.75 95.3	7.38 187	8.50 216	3.25 82.5	8.81 224
2-1/4-2-3/8	56-60	21.50 546	2.75 69.8	8.50 216	5.00 127	2.63 66.8	4.13 105	8.25 210	9.00 229	3.63 92.2	9.75 248
2-1/2-2-5/8	64-67	23.50 597	3.12 79.2	9.50 241	5.50 140	2.88 73.2	4.50 114	9.25 235	9.75 248	4.00 102	10.62 270
2-3/4-2-7/8	70-73	25.38 645	3.12 79.2	10.75 273	6.25 159	3.12 79.2	4.88 124	10.19 259	11.00 279	4.88 124	11.25 286
3-3-1/8	75-80	27.12 689	3.37 85.6	11.50 292	6.75 171	3.38 85.9	5.25 133	11.50 292	12.00 305	5.25 133	11.75 298
3-1/4-3-3/8	82-86	29.25 743	4.00 102	12.25 311	7.25 184	3.62 91.9	5.75 146	12.25 311	13.00 330	5.75 146	12.25 311
3-1/2-3-5/8	88-92	31.00 787	4.00 102	13.00 330	7.75 197	3.88 98.6	6.31 160	13.00 330	14.00 356	6.25 159	13.00 330
3-3/4-4	94-102	33.25 845	4.25 108	14.25 362	8.50 216	4.25 108	7.25 184	14.25 362	15.00 381	7.00 178	14.00 356

Closed grooved sockets meet the performance requirements of Federal Specification RR-S-550F, Type B. Termination efficiency 100% based on catalogue rope strength, for 6x7, 6x19 or 6x37 IPS, EIP, EEIP, RRL, FC or IWRC rope. Pin diameter at the eye must not exceed the companion open-socket pin.

04 — RIGGING EQUIPMENT

RESIN SOCKETING COMPOUND

A two-part cold-pour resin for spelter sockets — 100% termination efficiency with no hazardous molten metal, ideal for on-site socketing. For use on open and closed spelter sockets only. Follow the wire-rope end-termination manual for brooming length and the resin volume per rope size shown below.

KEY PROPERTIES

- ◆ 100% termination efficiency; no hazardous molten metal.
- ◆ Operating range -54 °C to +116 °C (-65 °F to +240 °F).
- ◆ Pour without booster pack: +6.7 °C to +43.3 °C.
- ◆ One booster pack: +1.7 °C to +8.9 °C; two: -2.8 °C to +1.7 °C.
- ◆ Store ≤ +20 °C, away from sunlight and ignition.

TYPE APPROVALS

LLOYD'S REGISTER	DNV	RINA	GERMANISCHER LLOYD
ABS	US COAST GUARD	US NAVY	ISO 17.558
DNV-05-E304			

KIT SIZES

SOCKET COMPOUND — KIT SIZES

KIT SIZE (CC)	KITS / CASE	WEIGHT EACH (LB)
100	20	0.62
250	12	1.25
500	12	2.54
1000	12	4.59
2000	6	9.00

FOR SPELTER SOCKETS ONLY

Pour open and closed spelter sockets only. Mix the full two-part kit — never a partial batch — and pour within the working temperature range, adding booster packs as needed. A 250 cc kit ≈ one cup.

GUIDE TO AMOUNT OF RESIN REQUIRED

ROPE 1/4" - 1"

ROPE (IN)	(MM)	RESIN (CC)
1/4	6-7	9
5/16	8	17
3/8	9-10	17
7/16	11	35
1/2	13	35
9/16	14	52
5/8	16	52
3/4	20	86
7/8	22	125
1	26	160

ROPE 1-1/8" - 2-1/4"

ROPE (IN)	(MM)	RESIN (CC)
1-1/8	28	210
1-1/4	32	350
1-3/8	36	350
1-1/2	40	420
1-5/8	42	495
1-3/4	44	700
1-7/8	48	700
2	51	1265
2-1/8	54	1265
2-1/4	56	1410

ROPE 2-3/8" - 4"

ROPE (IN)	(MM)	RESIN (CC)
2-3/8	60	1410
2-1/2	64	1830
2-5/8	67	1830
2-3/4	70	2250
3	76	3160
3-1/4	82	3795
3-1/2	88	4920
3-3/4	94	5980
4	102	7730

Resin volume is a guide for a single rope end socketed at the recommended brooming length. Socketing resin is a hazardous material regulated for transport by road, air and sea.

04 — RIGGING EQUIPMENT

ALUMINIUM FERRULES — EN 13411-3

Swaged aluminium ferrules form the standard factory eye on wire-rope slings — a 90% efficient termination when pressed to the correct die and length. The complete size range below covers rope from 2 mm to 60 mm, for both single and double (Flemish) constructions to EN 13411-3.



ALUMINIUM FERRULE — BEFORE-SWAGE LENGTH, AFTER-SWAGE LENGTH & DIAMETER (EACH CELL INCH OVER MM)

FERRULE — ROPE 2-19 MM

ROPE (MM)	BEFORE L	AFTER L	AFTER Ø
2	.39 9.9	.31 7.9	.26 6.6
3	.55 14.0	.47 11.9	.37 9.4
4	.71 18.0	.59 15.0	.45 11.4
5	.87 22.1	.75 19.0	.55 14.0
6	1.02 25.9	.87 22.1	.65 16.5
7	1.18 30.0	1.00 25.4	.75 19.0
8	1.34 34.0	1.14 29.0	.85 21.6
9	1.50 38.1	1.28 32.5	.95 24.1
10	1.65 41.9	1.42 36.1	1.04 26.4
11	1.81 46.0	1.55 39.4	1.14 29.0
12	1.97 50.0	1.69 42.9	1.24 31.5
13	2.13 54.1	1.83 46.5	1.34 34.0
14	2.28 57.9	1.97 50.0	1.44 36.6
16	2.60 66.0	2.24 56.9	1.63 41.4
18	2.83 71.9	2.44 62.0	1.78 45.2
19	3.07 78.0	2.64 67.1	1.93 49.0

FERRULE — ROPE 20-60 MM

ROPE (MM)	BEFORE L	AFTER L	AFTER Ø
20	3.23 82.0	2.78 70.6	2.03 51.6
22	3.54 89.9	3.03 77.0	2.22 56.4
24	3.86 98.0	3.31 84.1	2.42 61.5
26	4.17 106	3.58 90.9	2.62 66.5
28	4.49 114	3.86 98.0	2.82 71.6
32	5.12 130	4.41 112	3.21 81.5
36	5.75 146	4.96 126	3.60 91.4
40	6.38 162	5.51 140	4.00 102
44	7.02 178	6.06 154	4.40 112
48	7.66 195	6.61 168	4.80 122
52	8.30 211	7.17 182	5.20 132
56	8.94 227	7.72 196	5.60 142
60	9.57 243	8.27 210	6.00 152

Before/after lengths and diameters are nominal for correct die selection; always confirm against the press and ferrule manufacturer's data. Swage with the matched die only. Efficiency ≈ 90% to EN 13411-3 when correctly pressed.

04 — RIGGING EQUIPMENT

FLEMISH SLEEVES & SWAGE STUDS

The Flemish-eye sleeve is the strongest mechanical termination — the rope is unlaidd, re-laid into a Flemish eye, and a steel sleeve is pressed over the tails, giving 90–95% efficiency that does not depend on the sleeve alone. Swage studs and sockets give a clean threaded or button end for architectural and structural rope. The full size range covers rope from 5 mm to 60 mm.

FLEMISH STEEL SLEEVE (CARBON)

ROPE (MM)	SLEEVE	AFTER Ø (MM)	AFTER L (MM)
6	S-6	18	40
7	S-7	21	47
8	S-8	24	55
9	S-9	27	60
10	S-10	30	68
11	S-11	33	74
12	S-12	36	82
13	S-13	39	87
14	S-14	42	95
16	S-16	48	108
18	S-18	54	121
19	S-19	57	128
22	S-22	66	148
24	S-24	72	161
26	S-26	78	175
28	S-28	84	188
32	S-32	96	215
36	S-36	108	241
40	S-40	120	268
44	S-44	132	295
52	S-52	156	348
60	S-60	180	402

SWAGE STUD / BUTTON STOP

ROPE (MM)	THREAD	AFTER Ø (MM)	TYPE
5	M6	9.5	Threaded Stud
6	M8	11.5	Threaded Stud
8	M10	15.5	Threaded Stud
10	M12	19.0	Threaded Stud
12	M16	23.0	Threaded Stud
14	M18	26.6	Threaded Stud
16	M20	30.4	Threaded Stud
19	M24	36.1	Threaded Stud
22	M27	41.8	Threaded Stud
5	—	9.5	Button Stop
6	—	11.5	Button Stop
8	—	15.5	Button Stop
10	—	19.0	Button Stop
12	—	22.8	Button Stop
14	—	26.6	Button Stop
16	—	30.4	Button Stop
19	—	36.1	Button Stop

STRONGEST MECHANICAL EYE

A Flemish eye with a pressed steel sleeve develops 90–95% of the rope's breaking force — if the sleeve were to slip, the re-laid Flemish eye still holds the rope. This is why it is the default factory eye for heavy lifting slings.

Carbon-steel sleeves for general lifting; stainless for marine & architectural rope. After-swage dimensions are nominal for die selection. Swage with the matched die and verify go/no-go.

04 — RIGGING EQUIPMENT

GRADE 80 & 100 CHAIN SLINGS

Alloy lifting chain for the harshest duty — heat, abrasion and repeated heavy lifts where polyester and wire rope will not survive. Grade 100 carries about 25% more load than Grade 80 for the same chain diameter, to EN 818-4 / EN 1677 with a 4:1 design factor.

<p>G80</p> <p>GRADE 80</p> <p>The industry standard alloy chain. Robust, economical, widely stocked. EN 818-4, 4:1 factor.</p>	<p>G100</p> <p>GRADE 100</p> <p>~25% higher WLL at the same diameter — lighter assemblies for the same load. EN 818-4.</p>	<p>COMP</p> <p>COMPONENTS</p> <p>Clevis & eye sling hooks, self-locking hooks, grab/shortening hooks, connecting links, master links.</p>
--	--	---

CONFIGURATION FACTORS (FROM VERTICAL)

CHAIN SLING MODE FACTORS

CONFIGURATION	0-45°	45-60°
Single leg	1.0	1.0
Two leg	1.4	1.0
Three & four leg	2.1	1.5
Endless (basket)	1.6	1.1

WHY ALLOY CHAIN

Working temperature to +200°C (with WLL de-rating beyond +100°C), total resistance to abrasion and UV, field-repairable with certified components, and a simple visual inspection — stretch, nicks, gouges and wear at the bearing points.

WORKING WITH ALLOY CHAIN

DO

- ✓ De-rate the WLL above +100°C per the grade.
- ✓ Inspect the bearing points for stretch, nicks and gouges.
- ✓ Use only matched, certified components of one grade.
- ✓ Shorten legs with a proper grab / shortening hook.

DON'T

- ✗ Never mix Grade 80 and Grade 100 components.
- ✗ Never exceed the marked WLL or the mode factor.
- ✗ Never repair chain with bolts or by welding.
- ✗ Never use chain that is stretched, bent or heat-marked.

04 — RIGGING EQUIPMENT

ALLOY CHAIN SLING WLL — GRADE 80 / 100

Working load limit by chain size, hitch and angle, for Grade 80 (Spectrum 8) and Grade 100 (Spectrum 10) alloy chain. A 4:1 design factor agrees with ISO and ANSI B30.9, proof loaded at 2× the WLL. All values are in US tons of 2,000 lb. The leg angle is measured from the horizontal — a single leg at 90° is a straight vertical pull; the smaller the angle, the lower the rated capacity.

GRADE 80 (SPECTRUM 8) — WLL IN US TONS**GRADE 80 ALLOY CHAIN SLING — RATED WLL (US TONS OF 2,000 LB)**

CHAIN Ø (IN)	(MM)	SINGLE 90°	2-LEG 60°	2-LEG 45°	2-LEG 30°	3 & 4-LEG 60°	3 & 4-LEG 45°	3 & 4-LEG 30°
7/32"	6	1.25	1.80	1.50	1.25	3.25	2.65	1.88
1/4"	7	1.75	3.05	2.45	1.75	4.55	3.70	2.60
5/16"	8	2.25	3.90	3.20	2.25	5.85	4.75	3.40
3/8"	10	3.55	6.15	5.00	3.55	9.20	7.55	5.30
1/2"	13	6.00	10.40	8.50	6.00	15.60	12.75	9.00
5/8"	16	9.05	15.65	12.80	9.05	23.50	19.20	13.55
3/4"	20	14.15	24.50	20.00	14.15	36.75	30.00	21.20
7/8"	22	17.10	29.60	24.20	17.10	44.45	36.25	25.65
1"	26	23.85	41.30	33.70	23.85	61.95	50.60	35.75
1-1/4"	32	36.15	62.60	51.10	36.15	93.90	76.70	54.20

GRADE 100 (SPECTRUM 10) — WLL IN US TONS**GRADE 100 ALLOY CHAIN SLING — RATED WLL (US TONS OF 2,000 LB)**

CHAIN Ø (IN)	(MM)	SINGLE 90°	2-LEG 60°	2-LEG 45°	2-LEG 30°	3 & 4-LEG 60°	3 & 4-LEG 45°	3 & 4-LEG 30°
7/32"	6	1.60	2.75	2.25	1.60	4.15	3.40	2.40
1/4"	7	2.15	3.70	3.05	2.15	5.60	4.55	3.20
5/16"	8	2.85	4.95	4.05	2.85	7.40	6.05	4.25
3/8"	10	4.40	7.60	6.20	4.40	11.45	9.35	6.60
1/2"	13	7.50	13.00	10.60	7.50	19.50	15.90	11.25
5/8"	16	11.30	19.55	16.00	11.30	29.35	23.95	16.95
3/4"	20	17.65	30.50	24.95	17.65	45.85	37.45	26.48
7/8"	22	21.35	37.00	30.20	21.35	55.45	45.30	32.00
1"	26	29.85	51.70	42.20	29.85	77.55	63.30	44.78
1-1/4"	32	45.20	78.30	63.90	45.20	117.45	95.85	67.80

Rated loads converted from pounds to US tons (÷ 2,000) and not rounded up, so each figure is conservative. Design factor 4:1, proof loaded at 2× WLL, to ISO and ANSI B30.9. Angles measured from the horizontal — keep legs as steep as the lift allows for maximum WLL. Three-leg slings use the four-leg values. Grade 100 carries ~25% more than Grade 80 at the same diameter. De-rate above +100 °C. Use the marked capacity on the sling tag.

04 — RIGGING EQUIPMENT

HAND CHAIN BLOCKS & LEVER HOISTS

Compact, robust manual hoisting for daily industrial duty. The hand chain block is for vertical lifting from a fixed anchor; the lever hoist (ratchet) pulls and tensions in any orientation. Load chain to Grade 80/100, with safety-latch hooks top and bottom.

HAND CHAIN BLOCK

CAPACITY	STD LIFT (M)	CHAIN FALLS	HEADROOM (MM)	PULL (N)	WEIGHT (KG)
0.5 t	2.5	1	280	190	8.0
1.0 t	2.5	1	320	320	10.5
1.5 t	2.5	1	370	350	15.0
2.0 t	3.0	1	400	360	18.0
3.0 t	3.0	2	480	370	26.0
5.0 t	3.0	2	610	390	42.0
10.0 t	3.0	4	760	410	82.0
15.0 t	3.0	6	940	430	118.0
20.0 t	3.0	8	1180	450	165.0

LEVER HOIST (RATCHET)

CAPACITY	STD LIFT (M)	CHAIN FALLS	HEADROOM (MM)	LEVER (N)	WEIGHT (KG)
0.25 t	1.5	1	255	180	2.6
0.5 t	1.5	1	270	200	3.8
0.75 t	1.5	1	290	220	5.4
1.5 t	1.5	1	385	300	9.5
3.0 t	1.5	1	465	360	17.0
6.0 t	1.5	2	590	390	32.0
9.0 t	1.5	3	680	400	52.0

Standard lift heights shown; longer chains to order. Overload protection available. Headroom is hook-to-hook at zero lift. Inspect load chain, hooks and brake before every shift.

FEATURES & CONSTRUCTION

HAND CHAIN BLOCK

- ◆ Grade 80 load chain, zinc-plated and case-hardened.
- ◆ Weston-type mechanical load brake holds the load automatically.
- ◆ Forged, heat-treated steel hooks with safety latches top and bottom.
- ◆ Drop-forged hook swivels 360° on a thrust bearing.
- ◆ Lightweight all-steel housing; sealed gearing.
- ◆ Capacities 0.5 – 20 t; longer lift heights to order.

DO

- ✓ Anchor the block to a point rated above the load.
- ✓ Stand clear of and never under a suspended load.
- ✓ Pull the hand chain in line with the wheel.
- ✓ Lower under control on the brake — never free-drop.

LEVER HOIST (RATCHET)

- ◆ Pull, tension and position a load at any angle.
- ◆ Free-chaining lever for fast slack take-up.
- ◆ Grade 80/100 load chain with double-pawl brake.
- ◆ Compact, low-headroom body for tight access.
- ◆ 360° swivel hooks with safety latches.
- ◆ Capacities 0.25 – 9 t; ideal for site rigging.

DON'T

- ✗ Never lengthen the lever or hand chain to gain force.
- ✗ Never side-load the hook or tip-load the latch.
- ✗ Never use a hoist with a stretched or kinked chain.
- ✗ Never leave a load suspended unattended.

04 — RIGGING EQUIPMENT

TROLLEYS, CLAMPS & BEAM ANCHORS

The supporting cast. Push and geared beam trolleys carry the hoist along the beam; plate and beam clamps make a quick certified anchor for the hoist or a direct lift on steel plate.

BEAM TROLLEY

CAPACITY	BEAM FLANGE (MM)	TYPE	WEIGHT (KG)
0.5 t	50–127	Push	5.0
1.0 t	58–203	Push / Geared	9.0
2.0 t	66–203	Push / Geared	14.0
3.0 t	82–203	Geared	22.0
5.0 t	90–305	Geared	38.0
10.0 t	100–310	Geared	74.0
15.0 t	125–310	Geared	112.0
20.0 t	150–310	Geared	158.0

LIFTING & BEAM CLAMPS

CAPACITY	GRIP (MM)	TYPE
1.0 t	0–20	Vertical Plate
2.0 t	0–25	Vertical Plate
3.0 t	0–30	Vertical Plate
5.0 t	0–40	Vertical Plate
10.0 t	0–50	Vertical Plate
1.0–10 t	—	Beam / Girder Clamp
1.5–20 t	—	Horizontal Plate (pair)

Match the trolley to the beam flange width and the hoist capacity. Plate clamps must be sized to the plate thickness and never loaded beyond the marked grip range. All anchors certified with the hoist as a set.

CONSTRUCTION & SELECTION

BEAM TROLLEY

- ◆ Adjustable side plates fit a range of flange widths.
- ◆ Machined steel wheels on sealed bearings roll freely.
- ◆ Push or hand-geared travel; geared for heavy loads.
- ◆ Drop-stops and anti-tilt plates for safe travel.
- ◆ Galvanised finish for indoor or outdoor runways.

LIFTING & BEAM CLAMPS

- ◆ Forged, heat-treated cam grips harder under load.
- ◆ Vertical clamps lift plate on edge within the grip range.
- ◆ Horizontal clamps work only in matched pairs.
- ◆ Beam / girder clamps make a quick certified anchor.
- ◆ Marked grip range and WLL on every clamp body.

MATCHING THE SUPPORTING HARDWARE

SIZE IT TO THE BEAM

A trolley is only safe on the flange width and capacity it is set for. Measure the beam flange, match the trolley range, and set the wheel gap so the trolley rolls freely without climbing the flange.

DO

- ✓ Set the trolley wheel gap to the beam flange.
- ✓ Match the clamp to the plate thickness within its grip.
- ✓ Use horizontal plate clamps in certified pairs.
- ✓ Certify the trolley, clamp and hoist together as a set.

DON'T

- ✗ Never run a trolley off the end of an open beam.
- ✗ Never overload a clamp beyond its grip or WLL.
- ✗ Never lift on a single horizontal clamp.
- ✗ Never modify or weld a trolley or clamp body.



05

SERVICE & SUPPORT

Engineering, certification and a phone number that answers — before, during and after the lift.

ENGINEERED SOLUTIONS

PROOF-LOAD TESTING

ROPE IDENTIFICATION

ORDERING

GET IN TOUCH

NO MORE GUESSING FOR LIFTING

05 — SERVICE & SUPPORT

ENGINEERED SOLUTIONS

Some lifts can't be ordered from a chart. When the load is unusual, the geometry is tight, or the standard is critical, our engineering team designs, builds, proof-tests and certifies a bespoke assembly — and supports it through its working life.

01

DESIGN & CALCULATION

Sling-leg tension analysis, centre-of-gravity and angle calculations, fitting selection and a stamped engineering drawing for the lift.

02

FABRICATION

In-house swaging, splicing and assembly of wire-ropes, chain and polyester sets to the approved drawing, from certified raw material.

03

PROOF-LOAD TESTING

Calibrated test bed to several hundred tonnes; proof-load to the value the standard requires, with a serialised test certificate.

04

INSPECTION & RE-CERTIFICATION

Scheduled periodic inspection, NDT, and re-certification of slings and rigging to keep your site audit-ready.

± 1%

TEST-BED ACCURACY

24 h

QUOTE TURNAROUND

100%

SERIALISED CERTS

ONE PARTNER, WHOLE LIFT

From the rope on the drum to the shackle at the hook, every component in an engineered set is matched, rated and certified together — no mixed components, no guessing.

05 — SERVICE & SUPPORT

ORDERING & ROPE IDENTIFICATION

Tell us six things and we can quote. A complete wire-rope or sling specification removes the guesswork — and the description below is exactly how a rope is identified on its certificate.

HOW TO DESCRIBE A WIRE ROPE

FULL ROPE DESCRIPTION → “16 MM 6×36WS IWRC RHOL GALV 1960

#	ELEMENT	EXAMPLE
1	Diameter	16 mm
2	Construction	6×36WS
3	Core	IWRC
4	Lay	Right Hand Ordinary (RHOL)
5	Finish	Galvanized
6	Tensile grade	1960 N/mm ² (EIPS)
7	Standard	-
8	Length / fittings	20 m, both ends thimble eye

TO ORDER A SLING, STATE

- ◆ Working load limit (WLL) required.
- ◆ Hitch type & sling angle (vertical / choke / basket).
- ◆ Number of legs & effective working length.
- ◆ End fittings (eye, hook, master link, socket).
- ◆ Environment (heat, chemical, marine, UV).
- ◆ Standard & certification required.

EVERY SLING IS TAGGED

A durable identification tag carries the WLL, the serial / certificate number, the standard, and the date — so any inspector, any time, can trace the sling back to its material lot and test record.

Keep the certificate. A sling without a legible tag and a matching certificate must be withdrawn from service until re-inspected and re-certified.

A SLING WITHOUT A TAG IS SCRAP

The identification tag and its matching certificate are what make a sling legal to use and traceable to its material lot. If the tag is missing or unreadable, withdraw the sling until it is re-inspected and re-certified.

05 — SERVICE & SUPPORT

GET IN TOUCH

Talk to an engineer, not a call centre. Whether you need a single shackle, a 4-leg engineered set, or a site-wide inspection contract, the fastest route to the right answer is to call us with the load and the lift.

A

SALES & QUOTES

Tel: +66 (0)2 101 0323-4
 Line: @kcbslingth
 sales1@kcbsling.co.th

B

ENGINEERING

Design, calculation & bespoke assemblies.
 sales1@kcbsling.co.th

C

TESTING & CERTIFICATION

Proof-load, inspection & re-cert.
 sales1@kcbsling.co.th

KCB SLING (THAILAND) CO., LTD.

- ◆ Head Office & Workshop — Pathum Thani, Thailand
- ◆ Mon–Sat 08:00–17:00 · 24/7 engineering support
- ◆ www.kcbsling.co.th



NO MORE GUESSING FOR LIFTING

Send us the load weight, the lift geometry and the environment. We'll specify the rope, the sling and the hardware — rated, matched and certified — and stand behind every piece.



KCB SLING × TRACK

NO MORE GUESSING

PRODUCT CATALOG · WIRE ROPE · POLYESTER · RIGGING · ACCESSORIES

KCB SLING (THAILAND) CO., LTD.

WWW.KCBSLING.CO.TH